



关注杰曼微信公众号



关注杰曼抖音号



Facebook



Wechat



# 称重传感器选型手册

## Load Cell Selection Manual

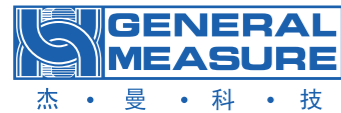

深圳市杰曼科技股份有限公司  
General Measure Technology Co.,Ltd.

总部地址: 深圳市南山区深圳国际创新谷6栋A座2208  
制造基地: 湖南省株洲市天元区新马动力创新园4.2期5号楼  
无锡分公司: 江苏省无锡市滨湖区滴翠路86号40601  
联系方式: 0731-22831558 | 0731-22831568  
联系邮箱: yyyang@szgmt.com  
官网网址: www.szgmt.com

Address: Room2208, Building 6, International Innovation Valley,  
Nanshan District, Shenzhen, Guangdong Province, P.R.China.  
Tel/Wechat: +86 185 6585 5789  
E-mail: xjlv@szgmt.com  
Website: www.gmweighing.com

# 企业简介

## ENTERPRISE PROFILE

**30<sup>+</sup>**  
年行业经验  
Industry Experience

**40<sup>+</sup>**  
个国家销售  
Country Sales

**200<sup>+</sup>**  
研发专利设计  
R&D Patent

**2000<sup>+</sup>**  
应用现场  
Application of the scene

杰曼科技成立于1993年，30年来专注于称重仪表、检重秤及定量称重单元等称重核心部件的研发生产及销售。

杰曼科技自主研发的产品凭借着高品质、高速度、高精度等性能，为锂电、粮食、饲料、橡塑、建材、物流等诸多行业的工业称重系统提供了高效、可靠的称重解决方案，赢得了国内外2000多家客户的认可。其多个产品通过CE/CPA/OIML等国际认证，全线产品严格按照国际标准进行研发、生产及认证。

2017年，在湖南株洲设立10000平方米生产制造基地，并成立株洲市杰曼科技有限公司，为了更好的服务客户，2022年在无锡设立分公司，产品远销全球40多个国家和地区。

在众多配套商、代理商及分销商心目中，杰曼称重产品早已是集知名度、品质和价格优势于一身的的首选品牌。

Founded in 1993, General Measure has been dedicated to developing, producing, and selling industrial weighing instruments, check weighers, and granule packing fillers for over 30 years.

The products are meticulously developed, manufactured, and certified in accordance with international standards. They have passed various certifications, such as CE/CPA/OIML.

In 2017, General Measure established a state-of-the-art manufacturing base spanning across 10,000m<sup>2</sup> and set up a subsidiary in Zhuzhou, Hunan province. For better serving clients, GM set a branch in Wuxi in 2022. Currently, General Measure proudly collaborates with 15 exclusive partners worldwide while catering to clients from more than 40 countries and regions. The trust of over 2,000 domestic and international customers serves as an affirmation of General Measure's excellence.



### 目录CONTENTS

#### 称重传感器Load Cell 03

##### 悬臂梁/波纹管称重传感Shear /Bending Beam Load Cell

GML-X8 F Series系列	04
GML-X8 B Series系列	05
GML-X8 Q Series系列	06
GML-X8 S Series系列	07
GML-B5 M Series系列 波纹管	09

##### 柱式称重传感器Canister Load Cell

GML-Z4 A Series系列	11
GML-Z4 D Series系列	13

##### S型传感器S Type Load Cell

GML-S3 E Series系列	14
GML-S3 A Series系列	15

##### 单点式传感器Single Point Load Cell

GML-D6 1260 Series系列	16
GML-D6 1241 Series系列	17
GML-D6 1022 Series系列	18
GML-D6 845 Series系列	19
GML-X11 K Series系列 箱式	20

#### 称重模块及附件Weighing Module 21

GML-M8系列 悬臂梁模块及附件 Weighing module with shear beam load cell	22
GML-M5系列 波纹管模块及附件 Weighing module with bending beam load cell	27
GML-M4系列 柱式模块及附件 Weighing module with canister load cell	28

# A

## 称重传感器 Load Cell



### 订货型号信息 Model Order Information:

Load cell type model (output signal)	Weighing range	Series	Material	Cable length	Accuracy	Anti-explosion
<b>GML-传感器类型及数字代码 (输出特性)</b>	<b>-量程-</b>	<b>系列号</b>	<b>材质</b>	<b>-线长</b>	<b>精度</b>	<b>防爆特性</b>
shear beam load cell: X8 bending beam load cell: B5 canister load cell: Z4 s type load cell: S3 single point load cell: D6 single point load cell: X11 pancake load cell: L7	悬臂梁为X8 波纹管为B5 柱式为Z4 S型为S3 单点式为D6 箱式为X11 轮辐式为L7	数字版: D Digital: D  模拟版: 不标注 Analog: blank	不锈钢: S Stainless steel: S  合金钢: C Alloy steel: C			防爆: Ex Anti-explosion: Ex  常规: 不标注 Normal: blank

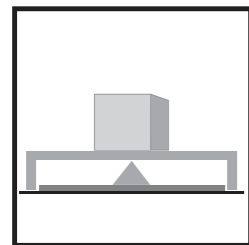

平台秤: 采用单/多只传感器  
Platform Scale with single/multiple load cells

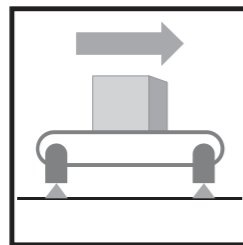

皮带秤  
Belt scale

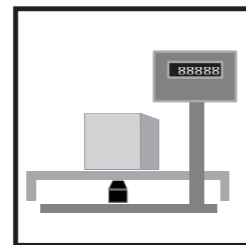

计价秤  
Commercial scale

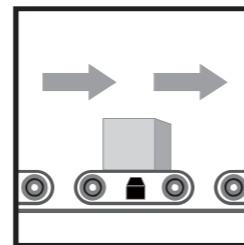

检重秤  
Check weigher

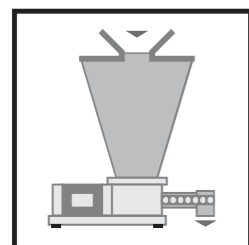

定量失重秤  
Loss-in-weight scale

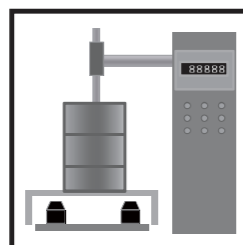

定量灌装秤  
Filling scale

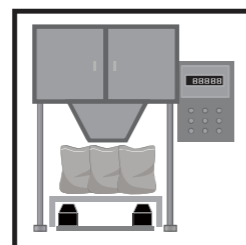

定量包装机  
Packing scale

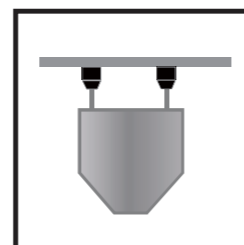

吊罐秤  
Crane scale

## GML-X8 F Series 系列



## 悬臂梁称重传感器

### Shear Beam Load Cell

结构紧凑, 安装高度低;  
焊接密封, 防护等级IP68;  
防爆等级: Ex ia IIC T4 Ga; Ex iaD 20 T135;  
模拟及数字版本可选。

Compact installation at minimum installation height;  
Welded sealing, IP68;  
Explosive-proof grade: Ex ia IIC T4 Ga; Ex iaD 20 T135;  
Analog or digital version selection.

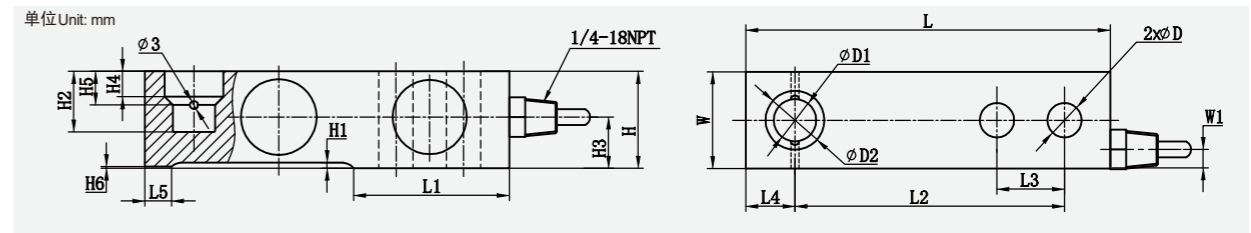

Cap(unit)t	D	D1	D2	H	H1	H2	H3	H4	H5	H6	L	L1	L2	L3	L4	L5	W	W1
0.1~1	13.0	22.2	15.9	30.2	1.8	17.3	16.0	4.8	7.9	0.38	133.4	57.7	101.6	25.4	15.4	6.4	30.7	6.1
2	13.0	22.2	15.9	36.6	6.0	22.9	19.6	9.5	12.7	/	136.7	57.9	101.6	25.4	18.4	/	36.8	6.1
3	15	22.2	15.9	36.6	4.0	22.9	19.6	9.5	12.7	/	136.7	57.9	104.6	25.4	18.4	/	39	6.1
5,7,5	19.3	34.9	22.2	42.9	4.5	29.3	22.6	10.8	17.8	/	171.5	73.8	133.4	38.1	21.4	/	42.9	6.1

### Specifications 技术说明

Item 项目	Unit 单位	Parameter 参数
Accuracy class 精度等级		C3
Maximum capacity(Emax) 额定载荷	t	0.1 / 0.2 / 0.5 / 1 / 2 / 3 / 5 / 7.5
Minimum LC verification interval(Vmin) 最小检定分度值	% of Emax	0.0200
Sensitivity(Cn)/Zero balance 灵敏度/零点平衡	mV/V	2.0±0.002/0±0.02
Temperature effect on zero balance (TK0) 温度对零点影响	% of Cn/10K	±0.0170
Temperature effect on sensitivity (TKc) 温度对灵敏度影响	% of Cn/10K	±0.0170
Hysteresis error(dhy) 滞后误差	% of Cn	±0.0180
Non-linearity(dlin) 非线性误差	% of Cn	±0.0167
Creep(dcr) over 30 min. 蠕变及蠕变恢复	% of Cn	±0.0167
Input (RLc) & Output resistance (R0) 输入&输出电阻	Ω	400±20 & 352±3
Nominal range of excitation voltage (Bu) 额定电压	V	5~15
Insulation resistance(Ris) at 50Vdc 绝缘电阻	MΩ	>5000
Service temperature range(Btu) 工作温度	°C	-30...+70
Safe load limit(EL) & Break load(Ed) 破坏载荷&安全承载	% of Emax	150 & 300
Protection class according to EN60529 (IEC 529) 保护等级		IP68
Material : Measuring element 材料:测量元件		Stainless or Avolly steel 合金钢和不锈钢可选
Cable fitting 电缆配件		Stainless steel or nickel-plated brass
Cable-sheath 电缆护套		PVC
Maximum capacity(Emax) 额定载荷	t	0.1 / 0.2 / 0.5 / 1      2 / 3      5 / 7.5
Deflection at Emax(Sno),approx.最大荷下的变形量	mm	<0.5      <0.5      <0.6
Weight(G),approx重量	kg	1.1      1.3      3.2
Cable 电缆: Diameter 直径 Φ6mm Length 长度	m	4.5      4.5      7

## GML-X8 B Series系列



## 悬臂梁称重传感器

Shear Beam Load Cell

结构紧凑，安装高度低；  
有过载保护与支撑杆，采取摆支撑有自复位功能；  
模拟及数字版本可选。

Compact installation at minimum installation height;  
With overload stop and stay rod,  
Self-restoring due to pendulum bearing;  
Analog or digital version selection.

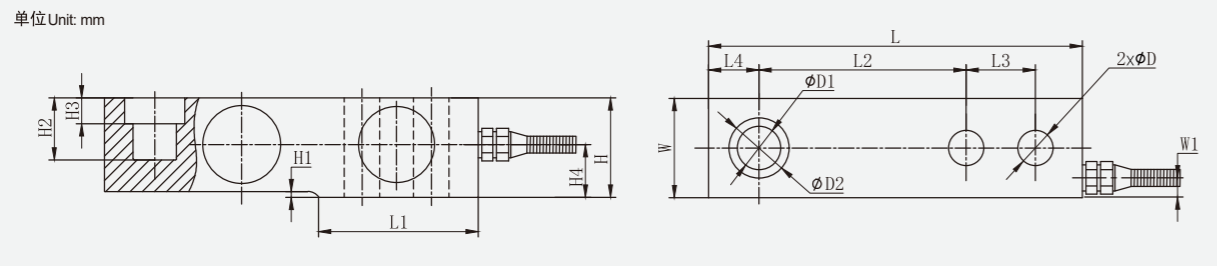

Cap(unit:t)	D	D1	D2	H	H1	H2	H3	H4	L	L1	L2	L3	L4	W	W1
0.5,1,2,3	12.7	15.9	26	36.6	2.1	22.9	4.2	19.1	136.6	57.9	76.2	25.4	18.4	36.8	7
5,7.5	19.3	22.2	34.9	42.9	2.4	29.3	11	23	171.5	73.8	95.2	38.1	21.4	42.9	6.5

地上衡、配料秤、料斗秤、  
平面台秤  
Floor scale, blending scale,  
hopper scale, platform scale

### Specifications 技术说明 Exc+(Red,红); Exc-(Black,黑); Sig+(Green,绿); Sig-(White,白); Sen+(Blue,蓝); Sen-(Yellow,黄)

Item 项目	Unit 单位	Parameter 参数
Accuracy class 精度等级		C3
Maximum capacity(Emax) 额定载荷	t	0.5 / 1 / 2 / 3 / 5 / 7.5
Minimum LC verification interval (Vmin) 最小检定分度值	% of Emax	0.0200
Sensitivity (Cn) / Zero balance 灵敏度/零点平衡	mV/V	2±0.002/0±0.02
Temperature effect on zero balance (TK0) 温度对零点影响	% of Cn/10K	±0.0170
Temperature effect on sensitivity (TKc) 温度对灵敏度影响	% of Cn/10K	±0.0170
Hysteresis error(dhy) 滞后误差	% of Cn	±0.0180
Non-linearity(dlin) 非线性误差	% of Cn	±0.0167
Creep(dcr) over 30 min.蠕变及蠕变恢复	% of Cn	±0.0167
Input(RLc) & Output resistance (Ro) 输入&输出电阻	Ω	400±10 & 352±3
Nominal range of excitation voltage (Bu) 额定电压	V	5~15
Insulation resistance (Ris) at50Vdc 绝缘电阻	MΩ	> 5000
Service temperature range (Btu) 工作温度	℃	-30~70
Safe load limit (EL) & Breaking load (Ed) 安全承载&破坏载荷	% of Emax	150 & 200
Protection class according to EN60529 (IEC 529) 保护等级		IP68
Material 材料		合金钢和不锈钢可选 Option: Alloy steel,Stainless steel.

Item 项目	Unit 单位	Parameter 参数
Maximum capacity (Emax) 额定载荷	t	0.5 / 1 / 2 / 3 / 5 / 7.5
Deflection at Emax (snom) ,approx 最大载荷下的变形量	mm	<0.5 / <0.5 / <0.6
Weight (G) , approx 重量	kg	1.1 / 1.3 / 3.2
Cable 电缆: Diameter 直径:Ø6mm Length 长度	m	3.5 / 5 / 7

## GML-X8 Q Series系列



## 悬臂梁称重传感器

Shear Beam Load Cell

结构紧凑，安装高度低；  
有过载保护与支撑杆，采取摆支撑有自复位功能；  
模拟及数字版本可选。

Compact installation at minimum installation height;  
With overload stop and stay rod,  
Self-restoring due to pendulum bearing;  
Analog or digital version selection.

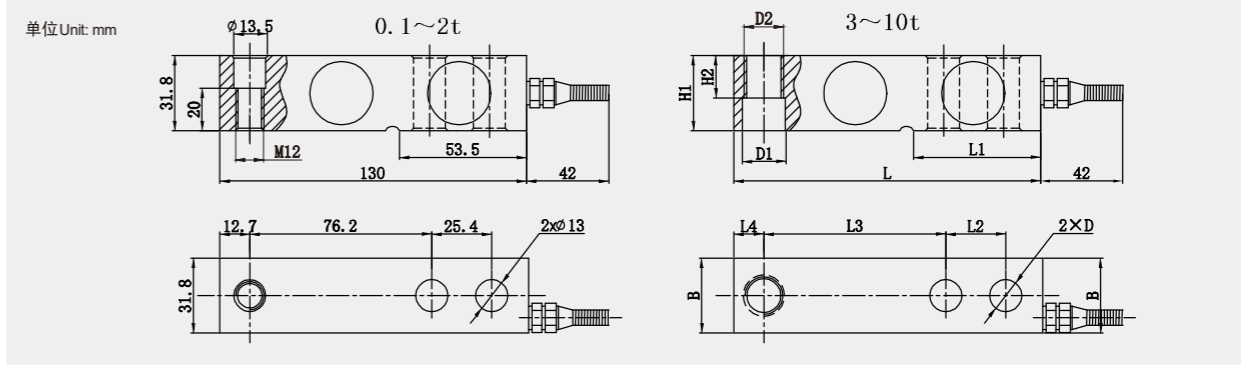

Cap(unit:t)	L	L1	L2	L3	L4	B	H1	H2	D	D1	D2
3~5	171.5	72.5	38.1	95.3	19	38.1	38.1	26	Ø20	Ø20	M18×1.5
7.5~10	225.5	102	50.8	124	25.3	50.8	50.8	25.4	Ø27	Ø27	M24×2

地上衡、配料控制系统、平面台秤  
Floor scale, blending control system, platform scale

### Specifications 技术说明 Exc+(Red,红); Exc-(Black,黑); Sig+(Green,绿); Sig-(White,白); Sen+(Blue,蓝); Sen-(Yellow,黄)

Item 项目	Unit 单位	Parameter 参数
Accuracy class 精度等级		C3
Maximum capacity(Emax) 额定载荷	t	0.1 / 0.3 / 0.5 / 1 / 2 / 3 / 5 / 7.5 / 10
Minimum LC verification interval (Vmin) 最小检定分度值	% of Emax	0.0100
Sensitivity (Cn) / Zero balance 灵敏度/零点平衡	mV/V	0.1~0.5t : 2.0±0.002 / 0±0.02 1~10t : 3.0±0.003 / 0±0.03
Temperature effect on zero balance(TKo) 温度对零点影响	% of Cn/10K	±0.0170
Temperature effect on sensitivity(TKc) 温度对灵敏度影响	% of Cn/10K	±0.0170
Hysteresis error(dhy) 滞后误差	% of Cn	±0.0180
Non-linearity(dlin) 非线性误差	% of Cn	±0.0167
Creep(dcr) over 30 min.蠕变及蠕变恢复	% of Cn	±0.0167
Input(RLc) & Output resistance (Ro) 输入&输出电阻	Ω	400±10 & 352±3
Nominal range of excitation voltage (Bu) 额定电压	V	5~15
Insulation resistance (Ris) at50Vdc 绝缘电阻	MΩ	≥5000
Service temperature range (Btu) 工作温度	℃	-40...+70
Safe load limit (EL) & Breaking load (Ed) 安全承载&破坏载荷	% of Emax	120 & 200
Protection class according to EN60529 (IEC 529) 保护等级		IP68 / IP67
Material 材料		合金钢和不锈钢可选 Option: Alloy steel,Stainless steel.

Item 项目	Unit 单位	Parameter 参数
Maximum capacity (Emax) 额定载荷	t	0.1~2.5 / 3 / 5 / 7.5 / 10
Deflection at Emax (snom) ,approx 最大载荷下的变形量	mm	<0.65 / <0.75 / <0.85
Weight (G) , approx 重量	kg	1.2 / 1.7 / 3.8
Cable 电缆: Diameter 直径:Ø6mm Length 长度	m	3 / 4.2 / 5

# GML-X8 S Series系列

## 悬臂梁称重传感器

Shear Beam Load Cell

结构紧凑，安装高度低；  
有过载保护与支撑杆，采取摆支撑有自复位功能；  
模拟及数字版本可选。

Compact installation at minimum installation height;  
With overload stop and stay rod,  
Self-restoring due to pendulum bearing;  
Analog or digital version selection.

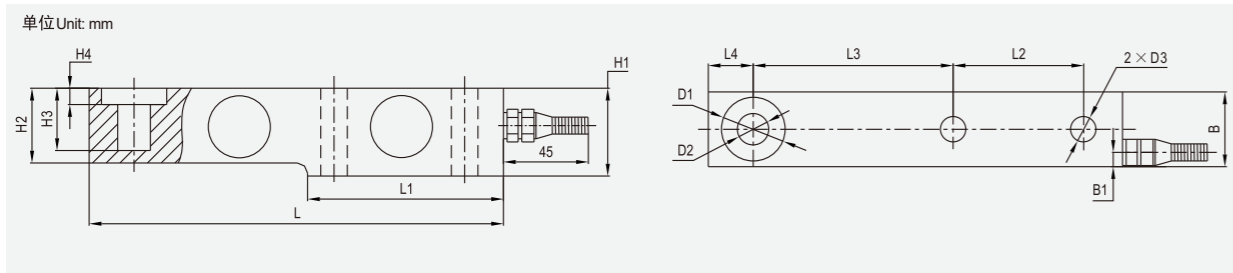

Cap(unit:t)	L	L1	L2	L3	L4	H1	H2/B	B1	H3	H4	D1	D2	D3
0.5,1,2,3	203	95	64	98	22	43	36.6	7	30.5	8	ø32	ø16	ø13
5,7,5,8	235	110	66	124	22	52	48	7	30	12	ø38	ø22	ø21
10,15	279	133	82	140	32	67	60	8.5	20	8.5	ø48	ø32	ø28
20,25	318	153	89	159	38	82.5	70	9.5	24	9.5	ø54	ø38	ø34

地上衡、配料秤、料斗秤、  
平台秤  
Floor scale, blending scale,  
hopper scale, platform scale

### Specifications 技术说明 Exc+ (Red,红); Exc-(Black,黑); Sig+(Green,绿); Sig-(White,白);Sen+(Blue,蓝); Sen-(Yellow,黄)

Item 项目	Unit 单位	Parameter 参数
Accuracy class 精度等级		C3
Maximum capacity(Emax) 额定载荷	t	0.5 / 1 / 2 / 3 / 5 / 7.5 / 8 / 10 / 15 / 20 / 25
Minimum LC verification interval(Vmin) 最小检定分度值	% of Emax	0.0100
Sensitivity(Cn)/Zero balance 灵敏度/零点平衡	mV/V	2.0±0.002/0±0.02
Temperature effect on zero balance (TK0) 温度对零点影响	% of Cn/10K	±0.0170
Temperature effect on sensitivity (TKc) 温度对灵敏度影响	% of Cn/10K	±0.0170
Hysteresis error(dhy) 滞后误差	% of Cn	±0.0180
Non-linearity(dlin) 非线性误差	% of Cn	±0.0167
Creep(dcr) over 30 min. 蠕变及蠕变恢复	% of Cn	±0.0167
Input (RLc) & Output resistance (RO) 输入&输出电阻	Ω	400±10 & 352 ±3
Nominal range of excitation voltage (Bu) 额定电压	V	5~12
Insulation resistance(Ris) at 50Vdc 绝缘电阻	MΩ	>5000
Service temperature range(Btu) 工作温度	°C	-30~70
Safe load limit(EL) & Break load(Ed) 破坏载荷&安全承载	% of Emax	150 & 300(0.5t~5t);120&200(8t~25t)
Protection class according to EN60529 (IEC 529) 保护等级		500kg:IP67;1t~25t:IP68

Material 材料	合金钢和不锈钢可选 Option: Alloy steel,Stainless steel.												
Maximum capacity(Emax) 额定载荷	t	0.5,1,2,3	3	5	7.5/8	10	15	20	25				
Deflection at Emax(Sno),approx.最大荷下的变形量	mm	<1	<1.2	<1.5	<1.2	<1.5							
Weight (G) , approx 重量	kg	2.2	4.2	8.0	11.5								
Cable 电缆: Diameter 直径:ø6mm Length 长度	m	2.6	3.5	5.2	7	12	12						

# GML-X8 S Series Assembly Drawing系列总装图

总装图 A  
Assembly Drawing A

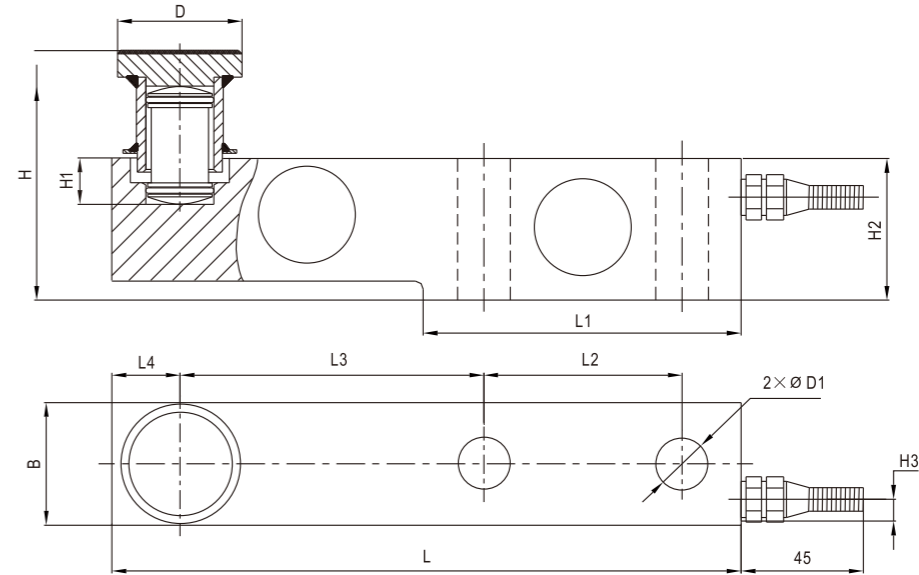

Cap(unit:t)	L	L1	L2	L3	L4	B	H	H1	H2	H3	D	D1
0.5,1,2,3	203	95	64	98	22	36.6	58	30.5	43	7	ø35	ø13
5,7,5,8	235	110	66	124	22	48	81	30	52	7	ø42	ø21
10,15	279	133	82	140	32	60	128	20	67	8.5	ø57	ø28
20,25	318	153	89	159	38	70	144	24	82.5	9.5	ø70	ø34

总装图 B  
Assembly Drawing B

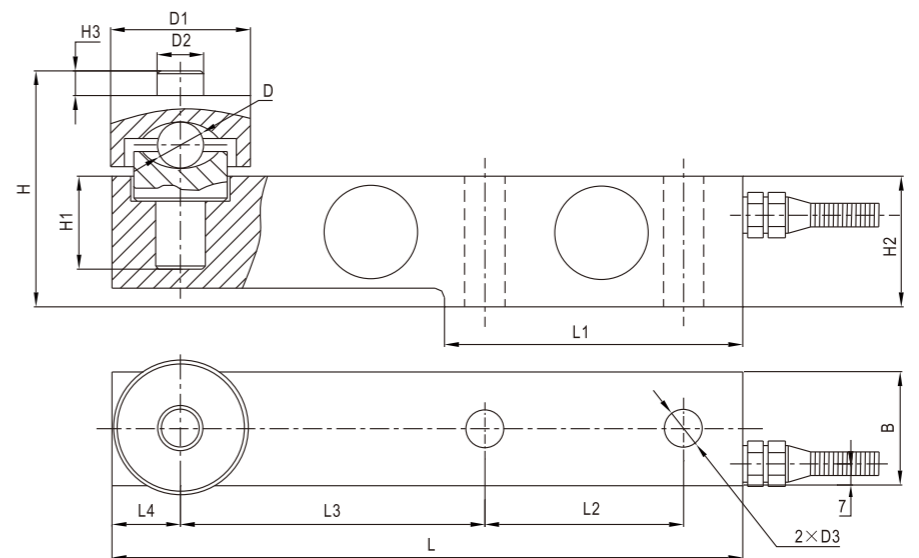

Cap(unit:t)	L	L1	L2	L3	L4	B	H	H1	H2	H3	D	D1	D2	D3
0.5,1,2,3	203	95	64	98	22	36.6	79	30.5	43	9	ø16	ø45	ø15	ø13
5,7,5,8	235	110	66	124	22	48	104	30	52	10	ø25	ø52	ø21	ø21

## GML-B5 M Series系列



## 波纹管称重传感器

Bending Beam Load Cell

结构紧凑, 安装高度低, 防护等级IP68;  
防爆等级: Ex ia IIC T4 Ga ; Ex iaD 20 T135;  
模拟及数字版本可选。

Compact installation at minimum installation height, IP68;  
Explosive-proof grade: Ex ia IIC T4 Ga ; Ex iaD 20 T135;  
Analog or digital version selection.

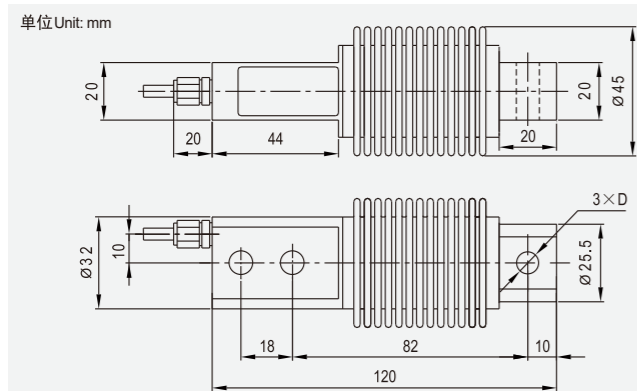

Cap(unit:kg)	D
10,20,50,75,100,200,250	ø 8.2
300,500	ø10.2

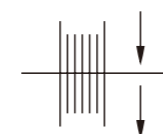

料斗秤、皮带秤、配料系统  
hopper scale, belt scale, blending system

### Specifications 技术说明 Exc+(Red,红); Exc-(Black,黑); Sig+(Green,绿); Sig-(White,白); Sen+(Blue,蓝); Sen-(Yellow,黄)

Item 项目	Unit 单位	Parameter 参数
Accuracy class 精度等级		C3
Maximum capacity(Emax) 额定载荷	kg	10 / 20 / 50 / 75 / 100 / 200 / 250 / 300 / 500
Minimum LC verification interval(Vmin) 最小检定分度值	% of Emax	0.0100
Sensitivity(Cn)/Zero balance 灵敏度/零点平衡	mV/V	2±0.002/0±0.02
Temperature effect on zero balance (TK0) 温度对零点影响	% of Cn/10K	±0.0170
Temperature effect on sensitivity (TKc) 温度对灵敏度影响	% of Cn/10K	±0.0170
Hysteresis error(dhy) 滞后误差	% of Cn	±0.0180
Non-linearity(dlin) 非线性误差	% of Cn	±0.0167
Creep(dcr) over 30 min. 蠕变及蠕变恢复	% of Cn	±0.0167
Input (RLc) & Output resistance (RO) 输入&输出电阻	Ω	400±10 & 352±3
Nominal range of excitation voltage (Bu) 额定电压	V	5~12
Insulation resistance(Ris) at 50Vdc 绝缘电阻	MΩ	≥5000
Service temperature range(Btu) 工作温度	°C	-30~70
Safe load limit(EL) & Break load(Ed) 破坏载荷&安全承载	% of Emax	120 & 200
Protection class according to EN60529 (IEC 529) 保护等级		IP68
Material 材料		合金钢和不锈钢可选 Option: Alloy steel, Stainless steel.

Maximum capacity(Emax) 额定载荷	kg	10	20	50	75	100	200	250	300	500
Deflection at Emax(Sno), approx. 最大荷下的变形量	mm				0.31					0.39
Weight(G), approx. 重量	kg				0.5					
Cable 电缆: Diameter 直径 Φ5mm Length 长度	m				3					

## GML-B5 M Series Assembly Drawing系列总装图

1000kg

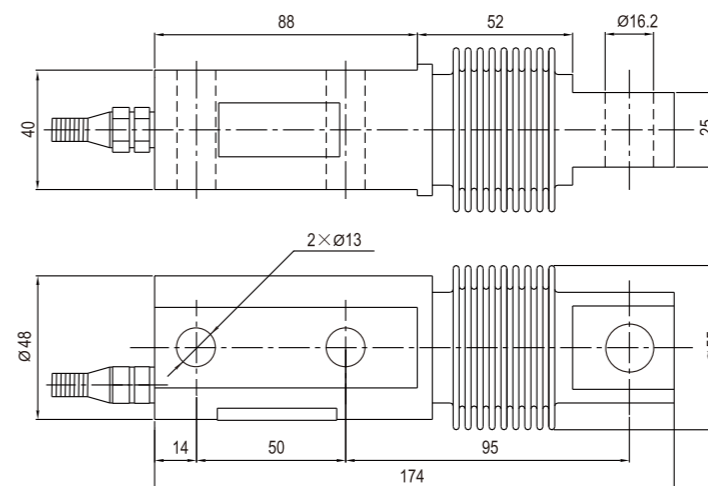

Cone and conical pan for Emax 10kg...1t.  
圆锥头, 圆锥面承载方式

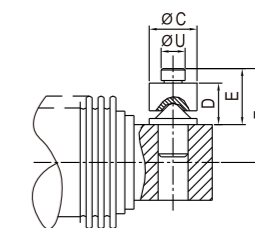

Cap(unit:kg)	C	D	E	U	X
10~200	15	16	21	8.1 <sup>0</sup> <sub>-0.05</sub>	26
300,500	18	24	32	11 <sup>0</sup> <sub>-0.05</sub>	34
1000	18	24	32	11 <sup>0</sup> <sub>-0.05</sub>	36.5

(10kg~500kg) 钢球压头承载方式:

Steel ball indenter loading method:

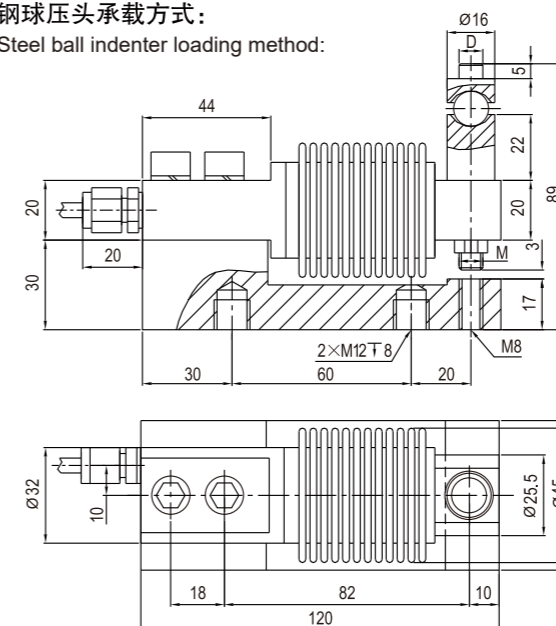

Cap(unit:kg)	D	M
10,20,30,50,75	ø8	M8
100,200,250	ø8	M8
300,500	ø10	M10

(10kg~500kg) 拉式附件结构图

Structure of pull type attachment:

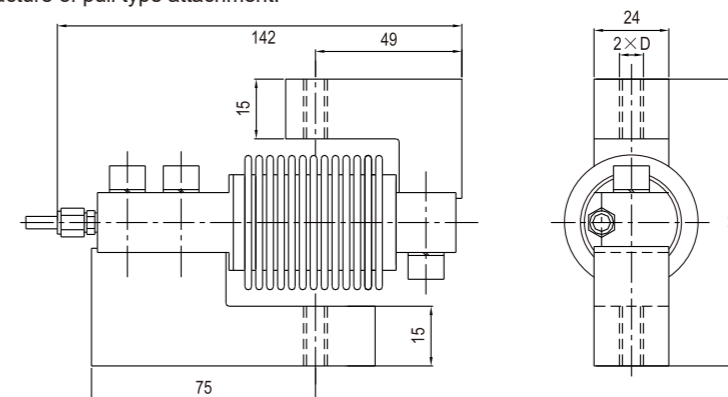

Cap(unit:kg)	D
10,20,30,50,75	M8
100,200,250	M8
300,500	M10

# GML-Z4 A Series系列



## 柱式传感器

Canister Load Cells

激光焊接IP68;  
自复位功能;  
经过角差预调整适合并联使用(按EN 45501);  
模拟及数字版本可选。

Laser welded,IP68;  
Self-restoring function;  
Optimized for paralld connection by corner pre-adjustment,  
Meets EMC/ESD requirements according to EN 45 501;  
Analog or digital version selection.



汽车衡、轨道衡、轴量秤、地上衡  
Truck scale,railway scale,axle wheel scale,floor scale

### Specifications 技术说明 Exc+ (Red,红); Exc-(Black,黑); Sig+(Green,绿); Sig-(White,白);Sen+(Blue,蓝); Sen-(Yellow,黄)

Item 项目	Unit 单位	Parameter 参数
Accuracy class 精度等级		C3
Maximum capacity(Emax) 额定载荷	t	10 / 15 / 20 / 30 / 40 / 50
Minimum LC verification interval(Vmin) 最小检定分度值	% of Emax	0.0100
Sensitivity(Cn)/Zero balance 灵敏度/零点平衡	mV/V	2.0±0.002/0±0.02
Temperature effect on zero balance (TK0) 温度对零点影响	% of Cn/10K	±0.0170
Temperature effect on sensitivity (TKc) 温度对灵敏度影响	% of Cn/10K	±0.0170
Hysteresis error(dhy) 滞后误差	%of Cn	±0.0180
Non-linearity(dlin) 非线性误差	%of Cn	±0.0167
Creep(dcr) over 30 min. 蠕变及蠕变恢复	% of Cn	±0.0167
Input (RLc) &Output resistance (R0) 输入&输出电阻	Ω	700±20 & 703±3.5
Nominal range of excitation voltage (Bu) 额定电压	V	5~12
Insulation resistance(Ris) at 50Vdc 绝缘电阻	MΩ	>5000
Service temperature range(Btu) 工作温度	℃	-30~70
Safe load limit(EL) & Break load(Ed) 破坏载荷&安全承载	% of Emax	150 & 250
Protection class according to EN60529 (IEC 529) 保护等级		IP68
Material 材料		合金钢和不锈钢可选 Option: Alloy steel,Stainless steel.
Maximum capacity(Emax) 额定载荷	t	10 15 20 30 40 50
Min. scale verification (emin) according to En45501 [...#=#max. Number of load cells] 秤的最小检定分度值	kg	5 5 [6#] 10 [6#] 20 [8#] 20 [8#] [10#]
Recommended maximum weighing capacity of scale推荐秤的额定载荷	t	20 30 50 80 100 120 150 200
Deflection at Emax(Sno),approx.最大荷下的变形量	mm	0.55 0.55 0.65 0.75 0.85 0.85
Weight(G),approx重量	kg	2.8 3.2 3.2 3.6 3.6 3.8
Cable 电缆: Diameter 直径 Φ5mm Length 长度	m	10 12 12 14 16 16

Mounting variation: 安装方式:  
for (10~50)t

单位 Unit: mm

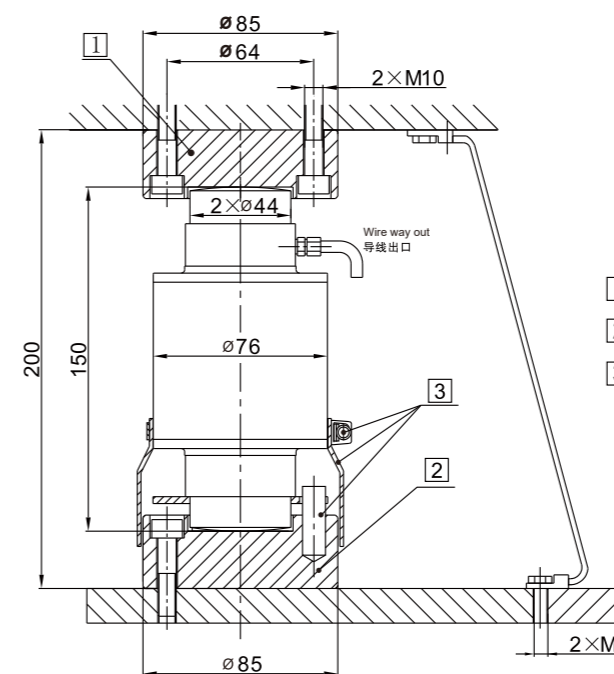

- ① GML-Z4 A/ZOU B1
- ② GML-Z4 A/ZOU2 B2
- ③ Dowel pin Φ10×30(rotation stop), flexible tube and tube clip enclosed in the packing of the load cell  
防旋转插销, 伸缩管与管夹在传感器包装中

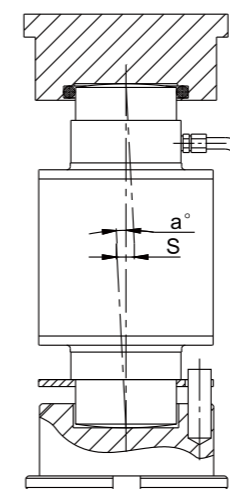

Wiring code (4-wire circuit)  
电缆芯线色标 (四线制)

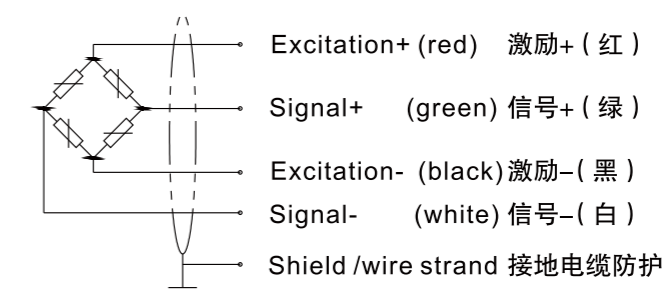

Cap	unit	t	10	15	20	25	30	40	50
R ball 球头半径	mm		130	130	160	160	160	180	180
amax 最大允许倾斜角度	" ° "		4.8	4.8	4.8	4.8	4.8	4.8	4.5
Smax 最大允许侧向偏移	mm		12	12	12	12	12	12	10.5
FR(%of applied load) 回复力 (施力大小的百分比)	at Smax		6.3	6.3	9.8	9.8	9.8	12	12
	at S=1mm		0.48	0.48	0.75	0.75	0.75	0.93	0.93



### 柱式传感器

Canister Load Cells

激光焊接IP68;  
自复位功能;  
经过角差预调整适合并联使用(按EN 45501);  
模拟及数字版本可选。

Laser welded,IP68;  
Self-restoring function;  
Optimized for paralld connection by corner pre-adjustment,  
Meets EMC/ESD requirements according to EN 45 501;  
Analog or digital version selection.

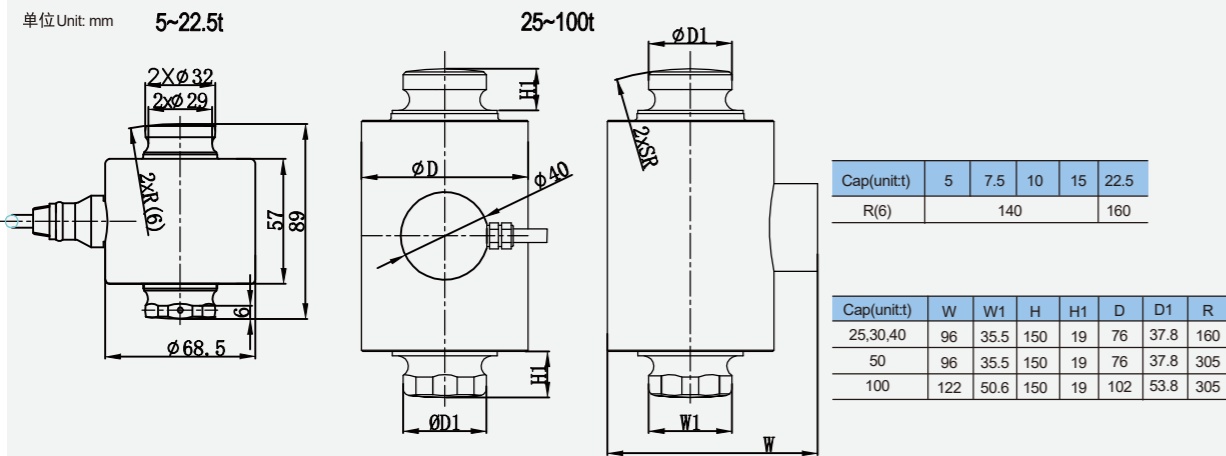

### Specifications 技术说明

Item 项目	Unit 单位	Parameter 参数
Accuracy class 精度等级		C3
Maximum capacity(Emax) 额定载荷	t	5 / 7.5 / 10 / 15 / 22.5 / 25 / 30 / 40 / 50 / 100
Minimum LC verification interval(Vmin)最小检定分度值	% of Emax	0.0100
Sensitivity(Cn)/Zero balance 灵敏度/零点平衡	mV/V	2.0±0.002 / 0±0.02
Temperature effect on zero balance (TK0) 温度对零点影响	% of Cn/10K	±0.0170
Temperature effect on sensitivity (TKc) 温度对灵敏度影响	% of Cn/10K	±0.0170
Hysteresis error(dhy)滞后误差	%of Cn	±0.0180
Non-linearity(dlin)非线性误差	%of Cn	±0.0167
Creep(dcr) over 30 min.蠕变及蠕变恢复	% of Cn	±0.0167
Input (RLc) &Output resistance (R0) 输入&输出电阻	Ω	1150±20 & 1005±5
Nominal range of excitation voltage (Bu) 额定电压	V	5~15
Insulation resistance(Ris) at 50Vdc 绝缘电阻	MΩ	>5000
Service temperature range(Btu) 工作温度	°C	-40..+70
Safe load limit(EL) & Break load(Ed) 破坏载荷&安全承载	% of Emax	150 & 250
Protection class according to EN60529 (IEC 529) 保护等级		IP68
Material:Measuring body+housing材料:测量元件+壳体		Stainless or alloy steel+Stainless steel 合金钢和不锈钢可选+不锈钢
Maximum capacity(Emax) 额定载荷	t	5   10   15   22.5   25~50   100
Deflection at Emax(Sno),approx.最大荷下的变形量	mm	<0.55   <0.6   <0.65   <0.7   <0.75   <0.85
Weight(G),approx重量	kg	1.5   3.8   6.3
Cable 电缆: Diameter 直径 Φ5mm Length 长度	m	12   16   16



### S型传感器

S Type Load Cells

结构紧凑,综合精度高;  
防护等级IP68。

Compact installation, high accuracy;  
IP68.

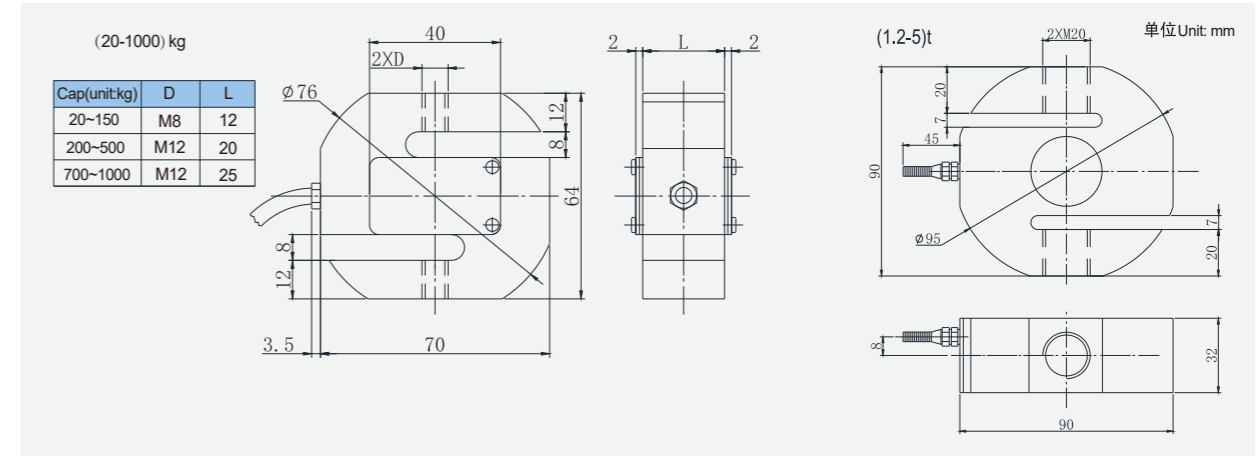

### Specifications 技术说明

Item 项目	Unit 单位	Parameter 参数
Accuracy class 精度等级		C3
Maximum capacity(Emax) 额定载荷	t	0.1 / 0.2 / 0.25 / 0.3 / 0.5 / 1 / 2 / 5
Minimum LC verification interval(Vmin) 最小检定分度值	% of Emax	0.0100
Sensitivity(Cn) 灵敏度	mV/V	2.0±0.002
Zero balance 零点平衡	mV/V	0±0.02
Temperature effect on zero balance (TK0) 温度对零点影响	% of Cn/10K	±0.0170
Temperature effect on sensitivity (TKc) 温度对灵敏度影响	% of Cn/10K	±0.0170
Hysteresis error(dhy) 滞后误差	%of Cn	±0.0180
Non-linearity(dlin) 非线性误差	%of Cn	±0.0167
Creep(dcr) over 30 min. 蠕变及蠕变恢复	% of Cn	±0.0167
Input (RLc) &Output resistance (R0) 输入&输出电阻	Ω	400±10 & 352 ±3
Nominal range of excitation voltage (Bu) 额定电压	V	5~12
Insulation resistance(Ris) at 50Vdc 绝缘电阻	MΩ	≥5000
Service temperature range(Btu) 工作温度	°C	-30~70
Safe load limit(EL) & Break load(Ed) 破坏载荷&安全承载	% of Emax	120 & 200
Protection class according to EN60529 (IEC 529) 保护等级		0.1t~1t:IP67;2t~5t:IP68
Material 材料		合金钢和不锈钢可选 Option: Alloy steel,Stainless steel.
Maximum capacity(Emax) 额定载荷	t	0.1,0.2,0.25,0.3,0.5   1   2   3   5
Deflection at Emax(Sno),approx.最大荷下的变形量	mm	0.15   0.25   0.45
Weight(G),approx重量	kg	0.6   0.8   1.5
Cable 电缆: Diameter 直径 Φ5mm Length 长度	m	5



### S型传感器 S Type Load Cells

结构紧凑，综合精度高；  
防护等级IP68。

Compact installation, high accuracy;  
IP68.

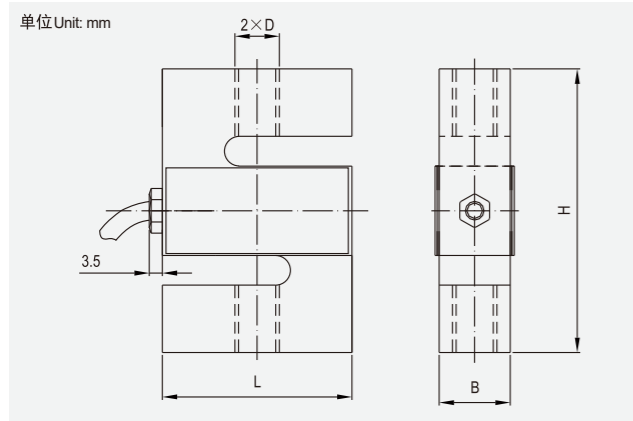

Cap(unit:t)	H	L	B	D
0.1,0.2,0.25,0.3,0.5	76.2	51	19.1	M12
1	76.2	51	25.4	M12
2,3,5	100.4	76.2	31.8	M20×1.5

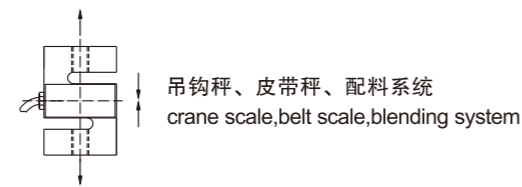

### Specifications 技术说明

Exc+(Red,红); Exc-(Black,黑); Sig+(Green,绿); Sig-(White,白); Sen+(Blue,蓝); Sen-(Yellow,黄)

Item 项目	Unit 单位	Parameter 参数
Accuracy class 精度等级		C3
Maximum capacity(Emax) 额定载荷	t	0.1 / 0.2 / 0.25 / 0.3 / 0.5 / 1 / 2 / 5
Minimum LC verification interval (Vmin) 最小检定分度值	% of Emax	0.01
Sensitivity (Cn) 灵敏度	mV/V	2.0±0.002
Zero balance 零点平衡	mV/V	0±0.02
Temperature effect on zero balance (TKo) 温度对零点影响	% of Cn/10K	±0.0170
Temperature effect on sensitivity (TKc) 温度对灵敏度影响	% of Cn/10K	±0.0170
Hysteresis error (dhy) 滞后误差	% of Cn	±0.0180
Non-linearity(dlin) 非线性误差	% of Cn	±0.0167
Creep(dcr) over 30 min. 蠕变及蠕变恢复	% of Cn	±0.0167
Input (RLc) & Output resistance (R0) 输入&输出电阻	Ω	400±10 & 352 ±3
Nominal range of excitation voltage (Bu) 额定电压	V	5~12
Insulation resistance (Ris) at 50Vdc 绝缘电阻	MΩ	≥5000
Service temperature range (Btu) 工作温度	C	-30~70
Safe load limit (EL) & Breaking load (Ed) 安全承载&破坏载荷	% of Emax	120 & 200
Protection class according to EN60529 (IEC 529) 保护等级		0.1t~1t:IP67; 2t~5t:IP68
Material 材料		合金钢和不锈钢可选 Option: Alloy steel, Stainless steel.

Maximum capacity (Emax) 额定载荷	t	0.1,0.2,0.25,0.3,0.5	1	2	3	5
Deflection at Emax (snom), approx 最大载荷下的变形量	mm	0.15	0.25	0.45		
Weight(G), approx 重量	kg	0.6	0.8	2.5		
Cable 电缆: Diameter 直径: φ5mm Length 长度	m	5				



### 单点式传感器 Single Point Load Cells

铝合金材质；  
防护等级: IP65；  
适合单个或者双个传感器结构的秤体的平台秤。

Alloy steel;  
IP65;  
Suitable for platform scale with single or dual load cells.

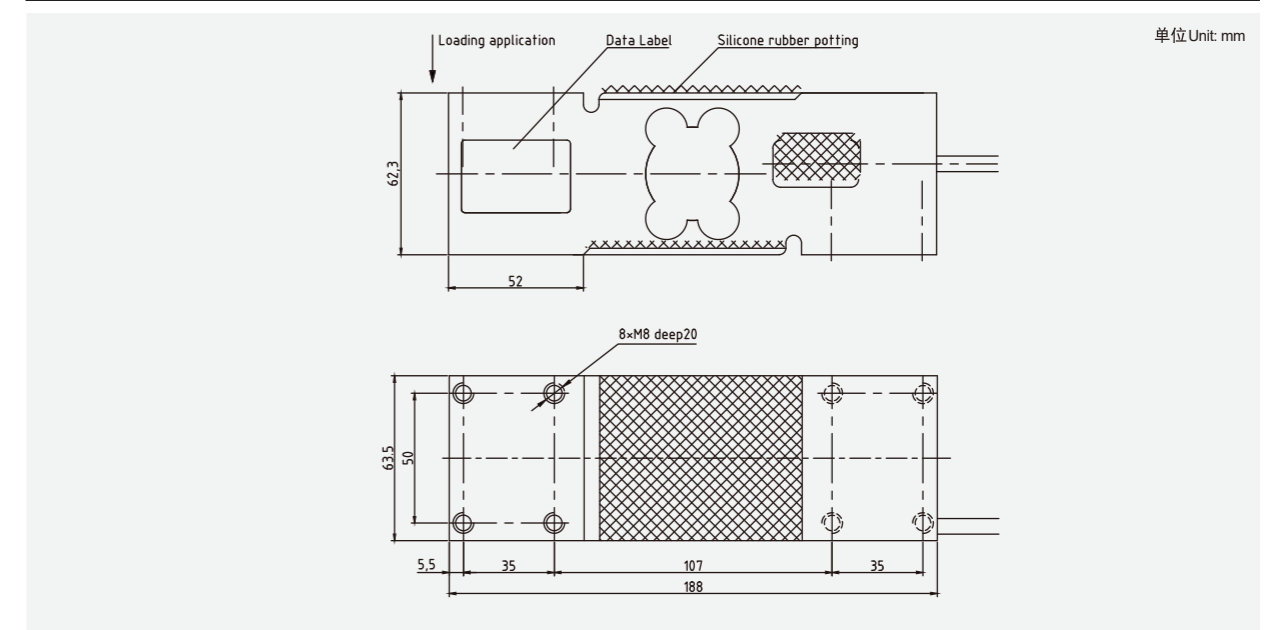

### Specifications 技术说明

Exc+激励正(Red,红); Exc-激励负(Black,黑); Sig+信号正(Green,绿); Sig-信号负(White,白)

Item 项目	Unit 单位	Parameter 参数
Accuracy class 精度等级		C3
Maximum capacity(Emax) 额定载荷	kg	150 / 250 / 500 / 750
Minimum LC verification interval(Vmin) 最小检定分度值	% of Emax	0.0023
Sensitivity(Cn)/Zero balance 灵敏度/零点平衡	mV/V	2.0±0.2/0±0.02
Temperature effect on zero balance (TKo) 温度对零点影响	% of Cn/10K	±0.017
Temperature effect on sensitivity (TKc) 温度对灵敏度影响	% of Cn/10K	±0.010
Hysteresis error(dhy) 滞后误差	% of Cn	<±0.017
Non-linearity(dlin) 非线性误差	% of Cn	<±0.017
Creep(dcr) over 30 min. 蠕变及蠕变恢复	% of Cn	<±0.017
Input (RLc) & Output resistance (R0) 输入&输出电阻	Ω	404±10 & 350±3
Nominal range of excitation voltage (Bu) 额定电压	V	5~15
Insulation resistance (Ris) at 50Vdc 绝缘电阻	MΩ	>5000
Service temperature range(Btu) 工作温度	C	-30...+70
Safe load limit(EL) & Break load(Ed) 破坏载荷&安全承载	% of Emax	150 & 300
Protection class according to EN60529 (IEC 529) 保护等级		IP65
Weight(G), approx 重量	kg	1.8
Cable 电缆: Diameter 直径 φ6mm Length 长度	m	2.5

## GML-D6 1241 Series系列



### 单点式传感器

Single Point Load Cells

铝合金材质;  
防护等级: IP65;  
适合单个或者双个传感器结构的秤体的平台秤。

Alloy steel;  
IP65;  
Suitable for platform scale with single or dual load cells.

## GML-D6 1022 Series系列



### 单点式传感器

Single Point Load Cells

铝合金材质;  
防护等级: IP65;  
适合单个或者双个传感器结构的秤体的平台秤。

Alloy steel;  
IP65;  
Suitable for platform scale with single or dual load cells.

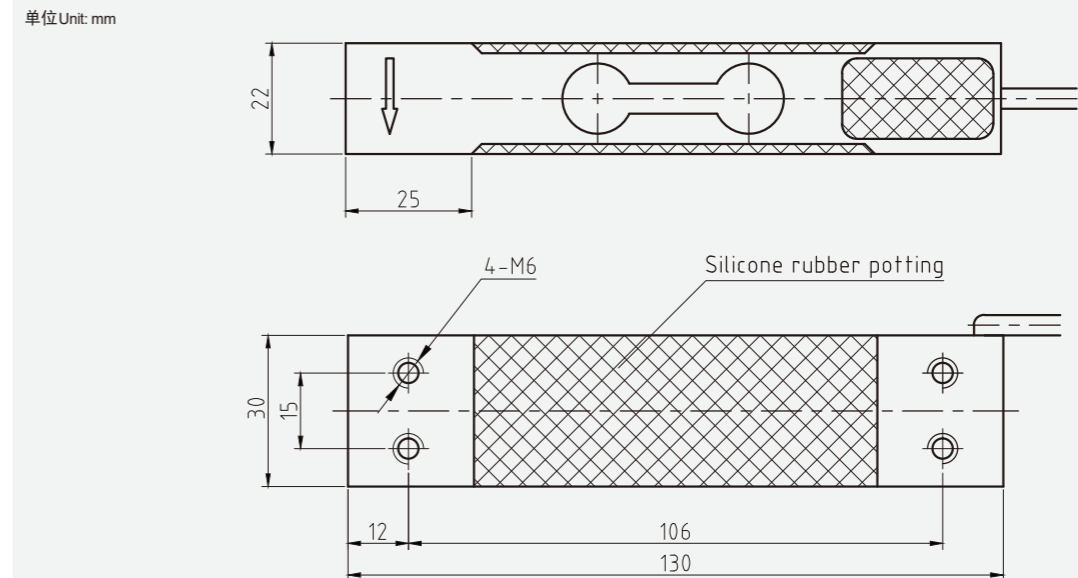
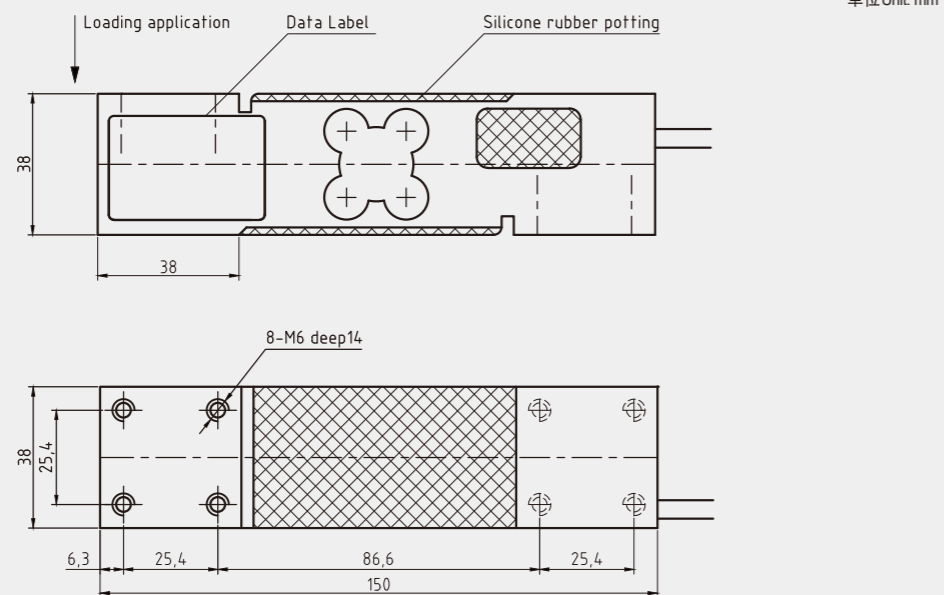

### Specifications 技术说明 Exc+激励正(Red,红);Exc-激励负(Black,黑);Sig+信号正(Green,绿);Sig-信号负(White,白)

Item 项目	Unit 单位	Parameter 参数
Accuracy class 精度等级		C3
Maximum capacity(Emax) 额定载荷	kg	50 / 100 / 200 / 250
Minimum LC verification interval(Vmin)最小检定分度值	% of Emax	0.0023
Sensitivity(Cn)/Zero balance 灵敏度/零点平衡	mV/V	2.0±0.2/0±0.02
Temperature effect on zero balance (TKo) 温度对零点影响	% of Cn/10K	±0.017
Temperature effect on sensitivity (TKc) 温度对灵敏度影响	% of Cn/10K	±0.010
Hysteresis error(dhy)滞后误差	%of Cn	<±0.017
Non-linearity(dlin)非线性误差	%of Cn	<±0.017
Creep(dcr) over 30 min.蠕变及蠕变恢复	% of Cn	<±0.017
Input (RLc) &Output resistance (Ro) 输入&输出电阻	Ω	404±10 & 350±3
Nominal range of excitation voltage (Bu)额定电压	V	5~15
Insulation resistance(Ris) at 50Vdc 绝缘电阻	MΩ	>5000
Service temperature range(Btu) 工作温度	°C	-30...+70
Safe load limit(EL) & Break load(Ed)破坏载荷&安全承载	% of Emax	150 & 300
Protection class according to EN60529 (IEC 529) 保护等级		IP65
Weight(G),approx重量	kg	0.6
Cable 电缆: Diameter直径Φ6mm Length 长度	m	2.0

### Specifications 技术说明 Exc+激励正(Red,红);Exc-激励负(Black,黑);Sig+信号正(Green,绿);Sig-信号负(White,白)

Item 项目	Unit 单位	Parameter 参数
Accuracy class 精度等级		C3
Maximum capacity(Emax) 额定载荷	kg	5 / 10 / 20 / 40 / 50
Minimum LC verification interval(Vmin)最小检定分度值	% of Emax	0.0023
Sensitivity(Cn)/Zero balance 灵敏度/零点平衡	mV/V	2.0±0.2/0±0.02
Temperature effect on zero balance (TKo) 温度对零点影响	% of Cn/10K	±0.017
Temperature effect on sensitivity (TKc) 温度对灵敏度影响	% of Cn/10K	±0.010
Hysteresis error(dhy)滞后误差	%of Cn	<±0.017
Non-linearity(dlin)非线性误差	%of Cn	<±0.017
Creep(dcr) over 30 min.蠕变及蠕变恢复	% of Cn	<±0.017
Input (RLc) &Output resistance (Ro) 输入&输出电阻	Ω	404±10 & 350±3
Nominal range of excitation voltage (Bu)额定电压	V	5~15
Insulation resistance(Ris) at 50Vdc 绝缘电阻	MΩ	>5000
Service temperature range(Btu) 工作温度	°C	-30...+70
Safe load limit(EL) & Break load(Ed)破坏载荷&安全承载	% of Emax	150 & 300
Protection class according to EN60529 (IEC 529) 保护等级		IP65
Weight(G),approx重量	kg	0.2
Cable 电缆: Diameter直径Φ6mm Length 长度	m	0.35[可选: 1.0]

## GML-D6 845 Series系列



## 单点式传感器 Single Point Load Cells

优质不锈钢, 综合精度高;  
四角偏差已补偿、安装简便快捷;  
激光焊接, IP等级IP69K;  
适用于罐装秤、食品设备过程称重等模拟及数字版本可选。  
模拟及数字版本可选。

High quality stainless steel, high accuracy;  
Four corner deviation, easy installation;  
Laser welding, IP69K;  
Suitable for silo scale, food equipment online weighing;  
Analog or digital version selection.

## GML-X11 K Series系列



## 箱式传感器 Single Point Load Cells

合金钢材质, 表面镀镍精度高;  
抗偏载能力强;  
防护等级IP67.

Alloy steel, surface nickel-plated, high accuracy;  
High capability for anti-biased load;  
IP67.

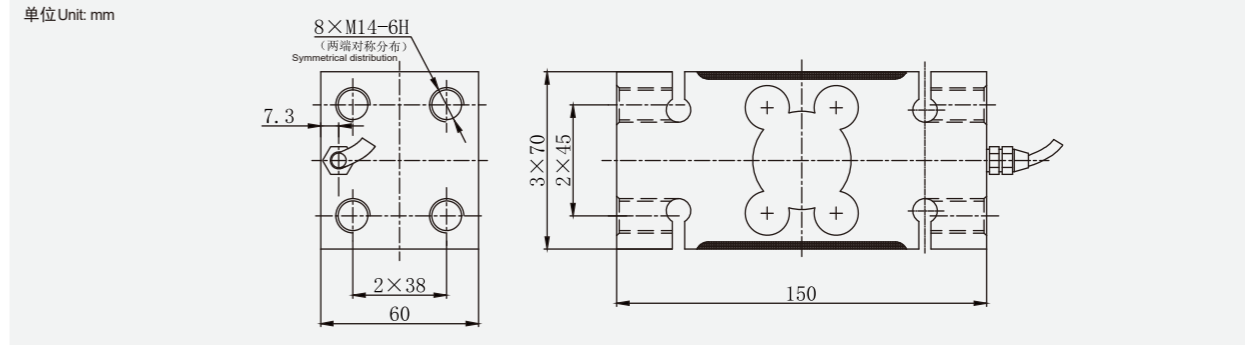
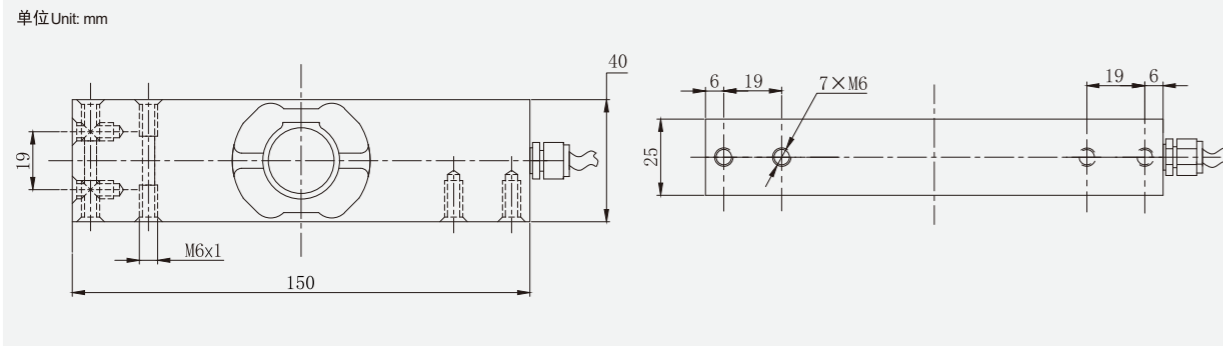

### Specifications 技术说明 Exc+激励正(Red,红);Exc-激励负(Black,黑);Sig+信号正(Green,绿);Sig-信号负(White,白)

Item 项目	Unit 单位	Parameter 参数
Accuracy class 精度等级		C3
Maximum capacity(Emax) 额定载荷	kg	10 / 20 / 50 / 100
Sensitivity(Cn)/Zero balance 灵敏度/零点平衡	mV/V	2.0±0.2 / 0±0.02
Temperature effect on zero balance (TK0) 温度对零点影响	% of Cn/10K	±0.0175
Temperature effect on sensitivity (TKc) 温度对灵敏度影响	% of Cn/10K	±0.0175
Hysteresis error (dhy) 滞后误差	%of Cn	±0.02
Non-linearity(dlin) 非线性误差	%of Cn	±0.0270
Creep(dcr) over 30 min. 蠕变及蠕变恢复	% of Cn	±0.0250
Eccentric error 四角误差	%	±0.0233
Input (RLc) &Output resistance (R0) 输入&输出电阻	Ω	400±30 & 352±3
Nominal range of excitation voltage (Bu) 额定电压	V	5~15
Insulation resistance (Ris) at 50Vdc 绝缘电阻	MΩ	>5000
Service temperature range (Btu) 工作温度	°C	-20...+50
Safe load limit (EL) & Breaking load (Ed) 安全承载&破坏载荷	% of Emax	150 & 200
Protection class according to EN60529 (IEC 529) 保护等级		IP67
Material 材料		不锈钢 Stainless steel.
Maximum capacity (Emax) 额定载荷	kg	10    20    50    100
Min. load cell verification inter(vmin) 最小检定分度值	g	2    5    10    20
Maximum platform size 最大秤台尺寸	mm	500×400
Deflection at Emax (snom), approx 最大载荷下的变形量	mm	<0.5
Weight(G), approx 重量	kg	1.5
Cable 电缆: Diameter 直径: Ø6mm Length 长度	m	3

### Specifications 技术说明 Exc+激励正(Red,红);Exc-激励负(Black,黑);Sig+信号正(Green,绿);Sig-信号负(White,白)

Item 项目	Unit 单位	Parameter 参数
Accuracy class 精度等级		C3
Maximum capacity(Emax) 额定载荷	kg	50 / 100 / 200 / 300 / 500 / 1000
Sensitivity(Cn)/Zero balance 灵敏度/零点平衡	mV/V	2.0±0.02/0±0.02
Temperature effect on zero balance (TK0) 温度对零点影响	% of Cn/10K	±0.0140
Temperature effect on sensitivity (TKc) 温度对灵敏度影响	% of Cn/10K	±0.0140
Hysteresis error (dhy) 滞后误差	% of Cn	±0.0150
Non-linearity(dlin) 非线性误差	% of Cn	±0.0167
Creep(dcr) over 30 min. 蠕变及蠕变恢复	% of Cn	±0.0167
Eccentric error 四角误差	%	±0.0233
Input (RLc) &Output resistance (R0) 输入&输出电阻	Ω	400±15 & 352±3
Nominal range of excitation voltage (Bu) 额定电压	V	5~15
Insulation resistance (Ris) at 50Vdc 绝缘电阻	MΩ	≥5000
Service temperature range (Btu) 工作温度	°C	-20~50
Safe load limit (EL) & Breaking load (Ed) 安全承载&破坏载荷	% of Emax	120 & 200
Protection class according to EN60529 (IEC 529) 保护等级		IP65
Material 材料		合金钢材质 Alloy steel.
Maximum capacity (Emax) 额定载荷	kg	50    100    200    300    500    750
Min. load cell verification inter(vmin) 最小检定分度值	g	20    20    50    50    100    100
Maximum platform size 最大秤台尺寸	mm	800×800
Deflection at Emax (snom), approx 最大载荷下的变形量	mm	<0.6
Weight(G), approx 重量	kg	4.3    4.5
Cable 电缆: Diameter 直径: Ø5mm Length 长度	m	3m
Mounting: Cylindrical head screw 装配: 内六角圆柱头螺钉		M14-10.9
Tightening torque 螺丝紧固力矩	N. m	35N.m

# B

## 称重模块及附件 Weighing module



### 订货型号信息 Model Order Information:

Load cell digital code GML-M匹配的传感器数字代码	Module type 模块类型	Accessory type 附件类型	Module Material 模块材质	Load cell Material 传感器材质	Weighing range 量程段
shear beam: 8 悬臂梁为8 bending beam: 5 波纹管为5 canister: 4 柱式为4 s type: 3 S型为3 pancake: 7 轮辐式为7	模块类型: 0, 1, 2, 3... Module type: 0, 1, 2, 3... 0为非模块部分附件 0 is non-module accessory	附件号: 0, 1, 2, 3... Accessory no.: 0, 1, 2, 3... 0为模块整体 0 is entire module	不锈钢: S Stainless steel: S 合金钢: C Alloy steel: C	不锈钢: S Stainless steel: S 合金钢: C Alloy steel: C	

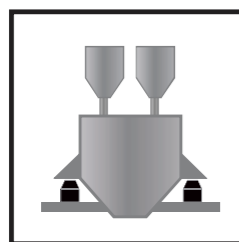

静态小量程: 料斗秤 料仓秤  
Hopper scale (small)

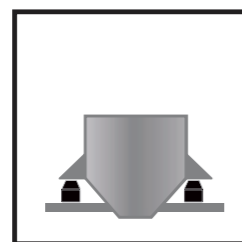

静态中量程: 料斗秤 料仓秤  
Hopper scale (medium)

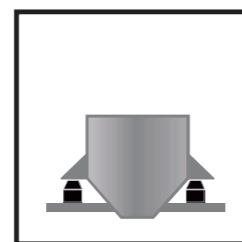

静态大量程: 料斗秤 料仓秤  
Hopper scale (large)

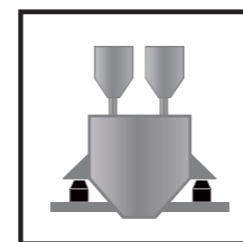

静态小量程: 搅拌斗秤  
Batching scale

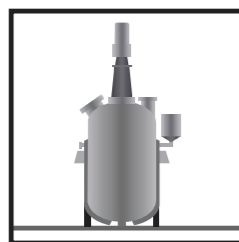

静态中量程: 反应釜秤  
Silo scale

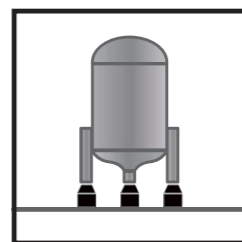

静态大量程: 筒仓秤  
Silo scale

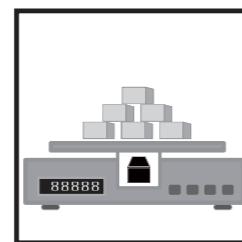

板坯秤 钢卷秤 废钢秤  
Platform scale

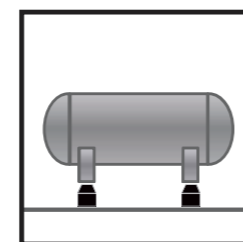

卧罐秤  
Tank scale

## GML-M810



### 悬臂梁模块

Weighing module with shear beam load cells

适用于GML-X8 F/B系列传感器;  
结构紧凑, 安装简便;  
防倾覆保护, 防过载保护;  
适用于动静载场合;  
不锈钢及合金钢材质可选。

GML-X8 F/B series are apply to this module;  
Compact installation, easy installation;  
Overturn and overload preventing protection;  
Suitable for static and online weighing;  
Stainless steel and alloy steel selection.

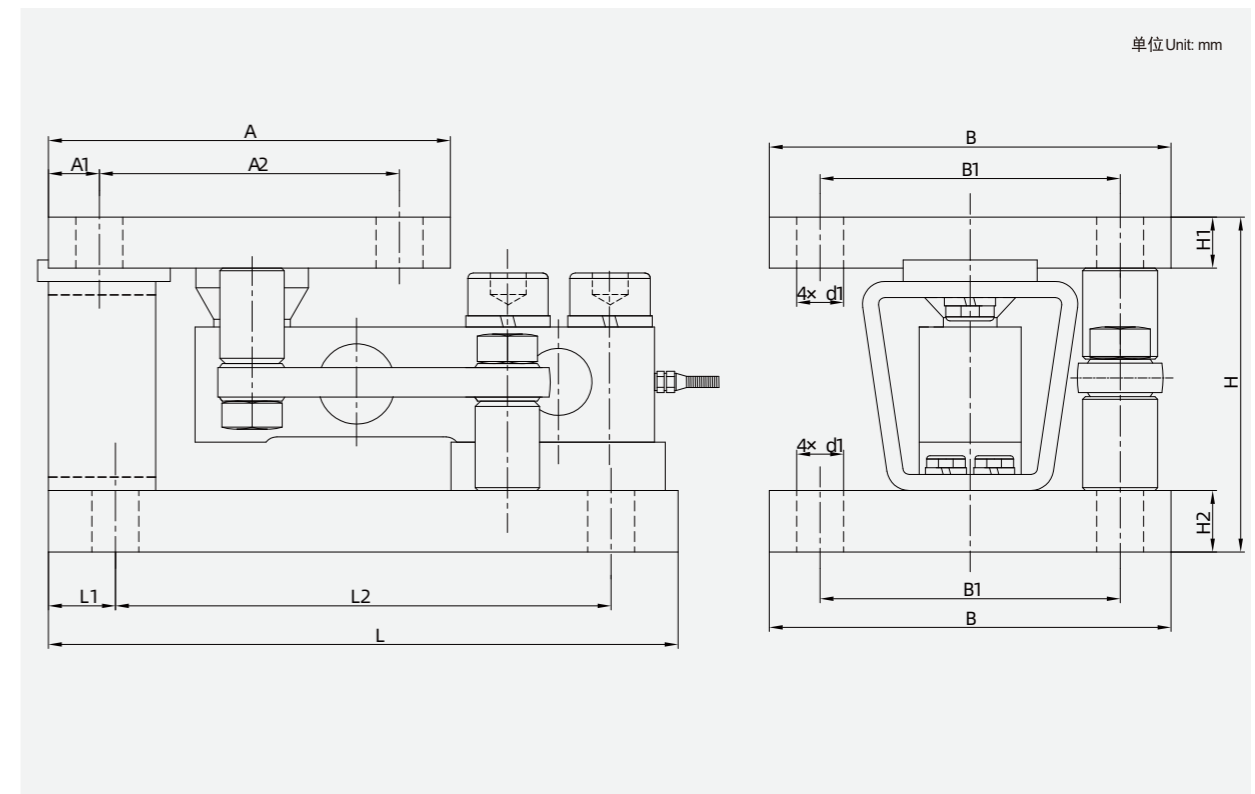

Cap(unit:t)	A	A1	A2	L	L1	L2	B	B1	H	H1	H2	d1
0.5,1,2	114	12.5	89	177.5	12.5	152.5	114	89	105	17.5	17.5	Ø11.2
3	114	12.5	89	177.5	12.5	152.5	114	89	108	19	19	Ø11.2
5	150	24.2	101.6	235	25.4	184.2	150	101.6	125	19	24	Ø17.5
7.5	150	24.2	101.6	235	25.4	184.2	150	101.6	135	24	29	Ø17.5
10	200	25	150	350	25	300	200	150	180	29	44	Ø22

# GML-M820



## 悬臂梁模块

Weighing module with shear beam load cells

适用于GML-X8 S系列传感器;  
结构紧凑, 安装简便;  
适用于动载场合;  
不锈钢及合金钢材质可选。

GML-X8 S series are apply to this module;  
Compact installation, easy installation;  
Suitable for online weighing;  
Stainless steel and alloy steel selection.

单位Unit: mm

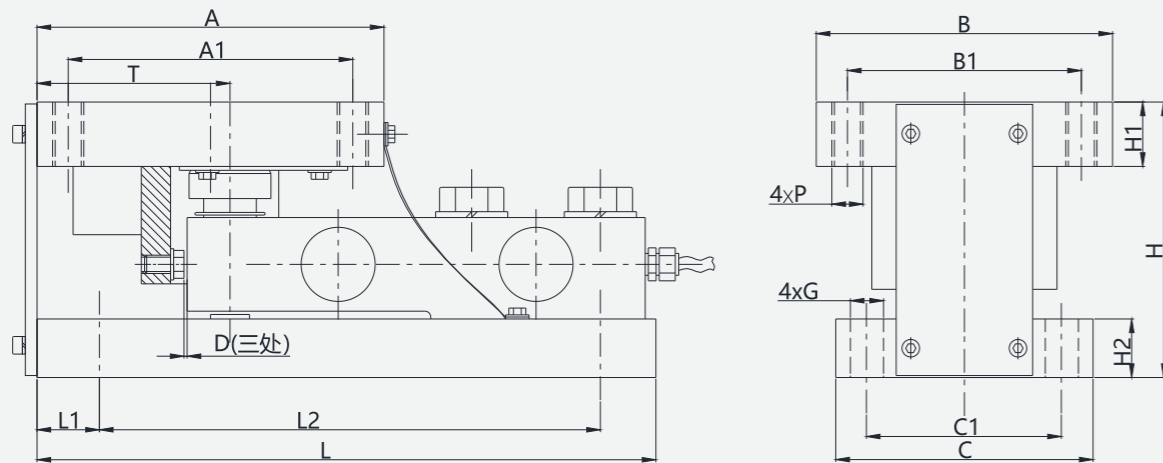

Cap(unit:t)	A	A1	B	B1	T	L	L1	L2	C	C1	H	H1	H2	P	G	D
0.5,1,2	150	124	128	102	96	286	32	226	112	80	107	19	19	M10	Ø13	1.6
3	150	124	128	102	96	286	32	226	112	80	107	24	23	M10	Ø13	1.6
5,8	178	146	152	120	99	318	32	257	152	102	146	38	30	M16	Ø17	1.6
10,15	184	152	154	122	105	360	32	295	154	106	216	45	45	M20	Ø21	3

### Mounting examples for weighing modules 安装方式

Cutting install 切向方式

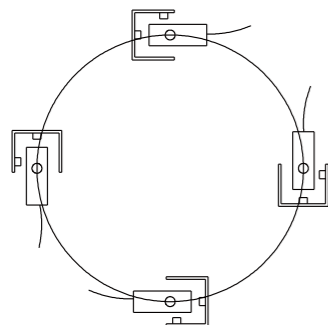

Rectangle Install 矩形方式

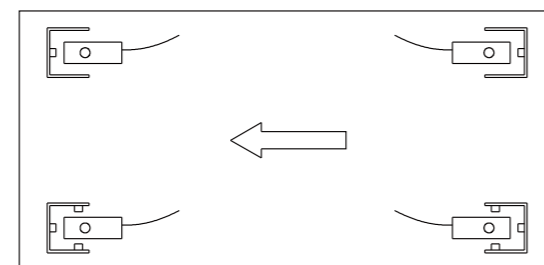

# GML-M830



## 悬臂梁模块

Weighing module with shear beam load cells

适用于GML-X8 S系列传感器;  
结构紧凑, 安装简便;  
适用于静载场合;  
不锈钢及合金钢材质可选。

GML-X8 S series are apply to this module;  
Compact installation, easy installation;  
Suitable for static weighing;  
Stainless steel and alloy steel selection.

单位Unit: mm

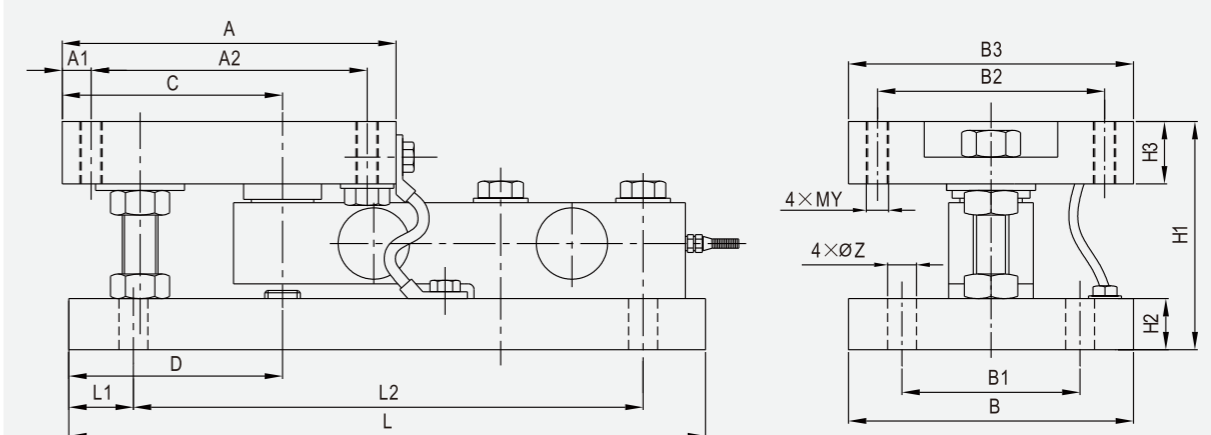

Cap(unit:t)	A	A1	A2	C	D	L	L1	L2	B	B1	B2	B3	H1	H2	H3	Y	Z
0.5,1,2	150	16	124	99	96	286	32	226	112	80	102	128	107	19	24	10	13
3	150	16	124	99	96	286	32	226	112	80	102	128	107	23	28	10	13
5,8	178	16	146	102	99	318	32	257	152	102	120	152	130	30	38	16	17
10,15	184	16	152	108	105	360	32	295	154	106	122	154	168	45	45	20	21

### Mounting examples for weighing modules 安装方式

Radial install 径向方式

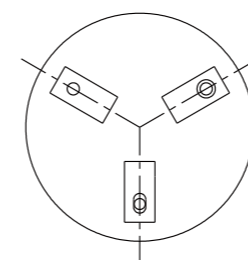

Cutting install 切向方式

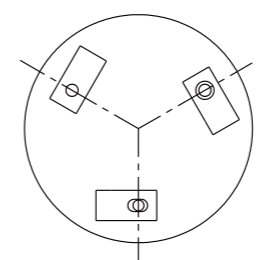

Rectangle install 矩形方式

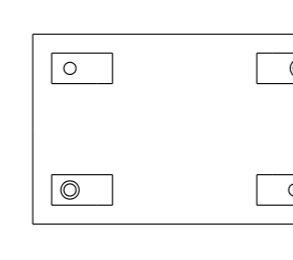

- Fixed Module 固定式
- ⊙ Semi-float Module 半浮动式
- ⊚ Float Module 全浮动式

## GML-M840

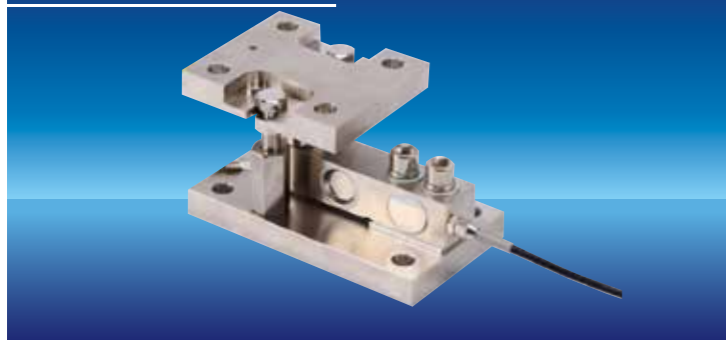

### 悬臂梁模块

Weighing module with shear beam load cells

适用于GML-X8 Q系列传感器;  
结构紧凑, 安装简便;  
不锈钢及合金钢材质可选。

GML-X8 Q series are apply to this module;  
Compact installation, easy installation;  
Stainless steel and alloy steel selection.

单位Unit: mm

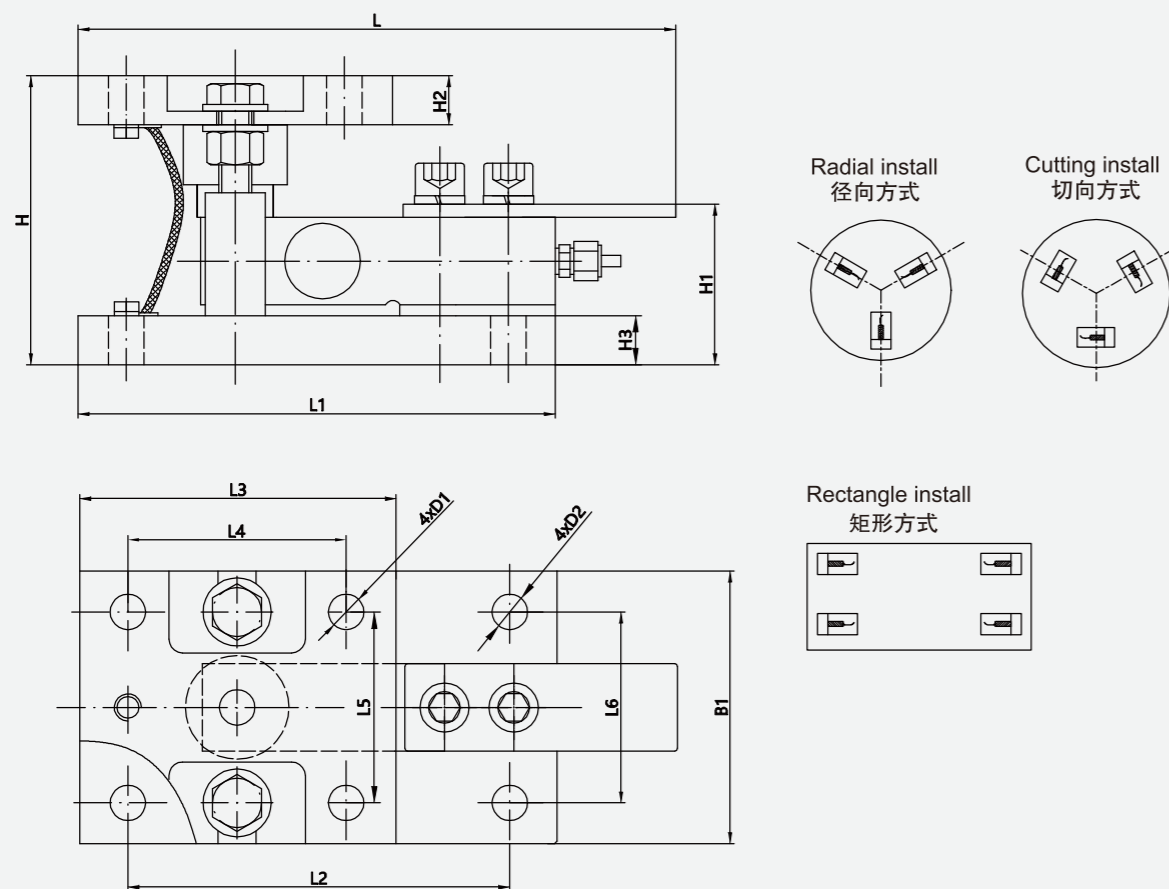

Cap(unit:t)	H	H1	H2	H3	B1	D1	D2	L	L1	L2	L3	L4	L5	L6
0.1~2	106	58	18	18	100	Φ13	Φ13	210	175	140	116	80	70	70
3,5	135	70	23	23	160	Φ17	Φ17	270	235	200	150	100	90	90
7.5,10	186.3	93.3	38	38	180	Φ26	Φ26	345.2	310	250	210.4	150.4	110	110

## GML-M850



### 悬臂梁模块

Weighing module with shear beam load cells

适用于GML-X8 Q系列传感器;  
结构紧凑, 安装简便;  
不锈钢及合金钢材质可选。

GML-X8 Q series are apply to this module;  
Compact installation, easy installation;  
Stainless steel and alloy steel selection.

单位Unit: mm

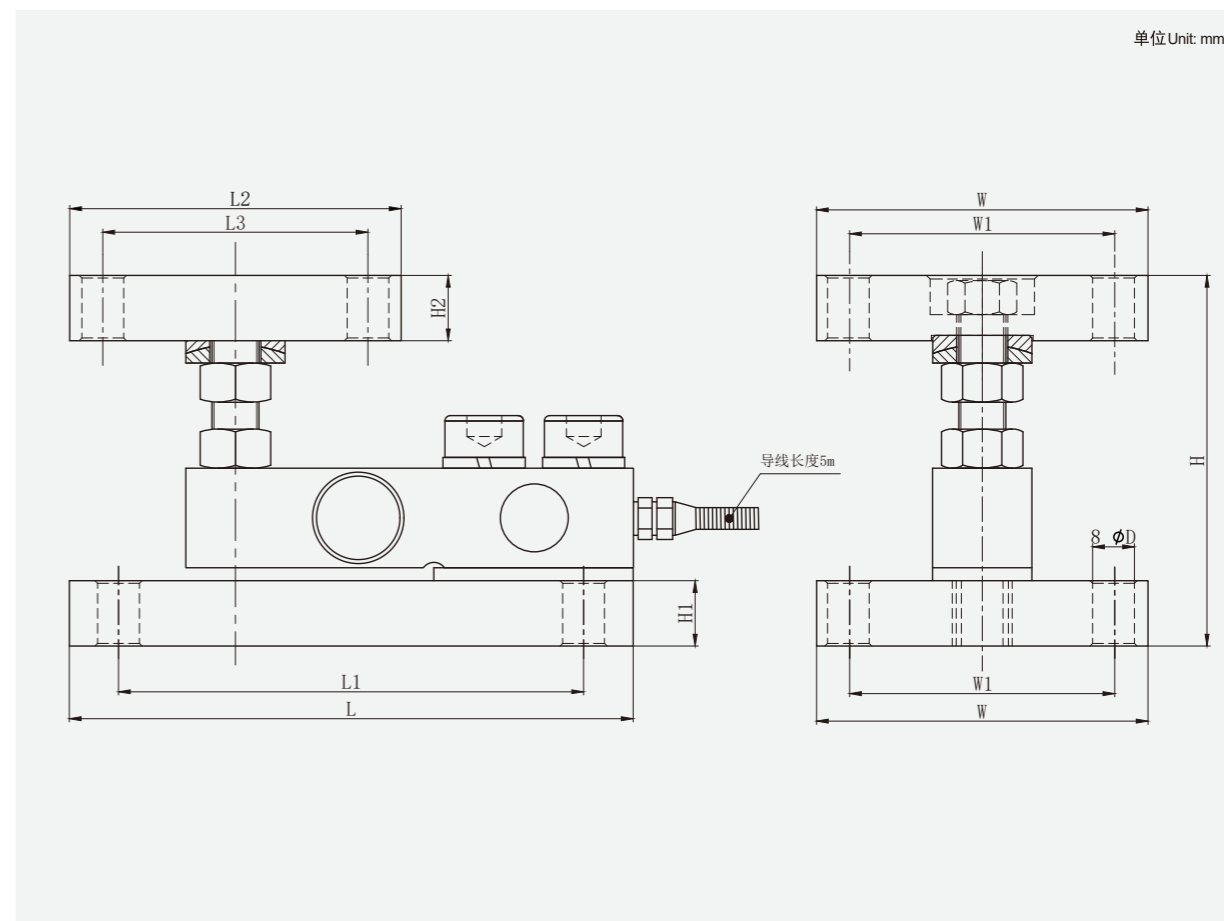

Cap(unit:t)	H	H1	H2	L	L1	L2	L3	W	W1	D
0.1~2	110-120	18	18	180.9	152.4	127	101.6	127	101.6	16
2.5t-5	138-151	26	26	216	177.8	127	101.6	127	101.6	16
7.5-10	195-220	38	38	285.8	235.8	177.8	127	177.8	127	21

## GML-M510

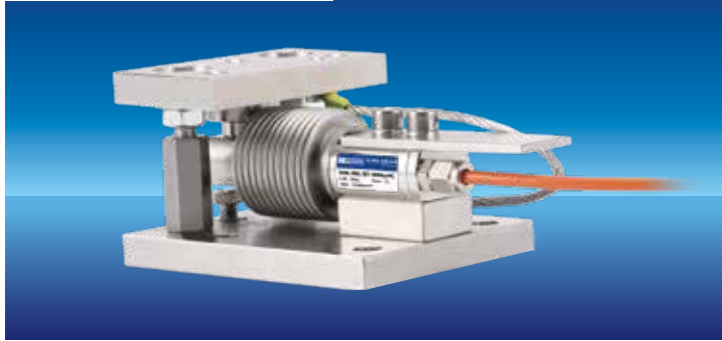

### 波纹管模块

Weighing module with bending beam load cells

适用于GML-B5 M系列传感器;  
结构紧凑, 安装简便;  
不锈钢及合金钢材质可选。

GML-B5 M series are apply to this module;  
Compact installation, easy installation;  
Stainless steel and alloy steel selection.

## GML-M420



### 柱式模块

Weighing module with canister load cells

适用于GML-Z4 D系列传感器;  
结构紧凑, 安装简便;  
不锈钢及合金钢材质可选。

GML-Z4 D series are apply to this module;  
Compact installation, easy installation;  
Stainless steel and alloy steel selection.

单位Unit: mm

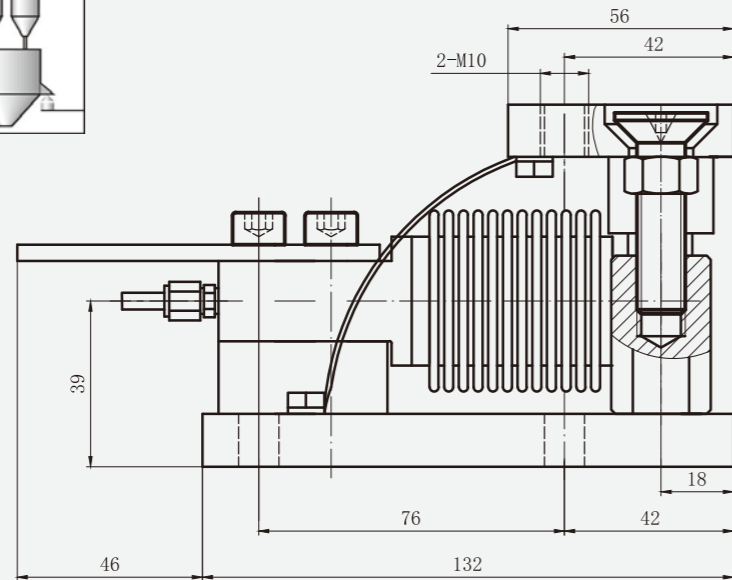
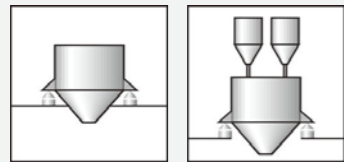
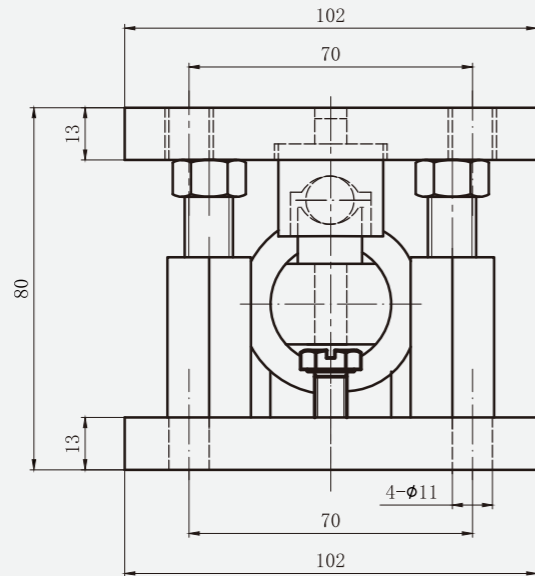

单位Unit: mm

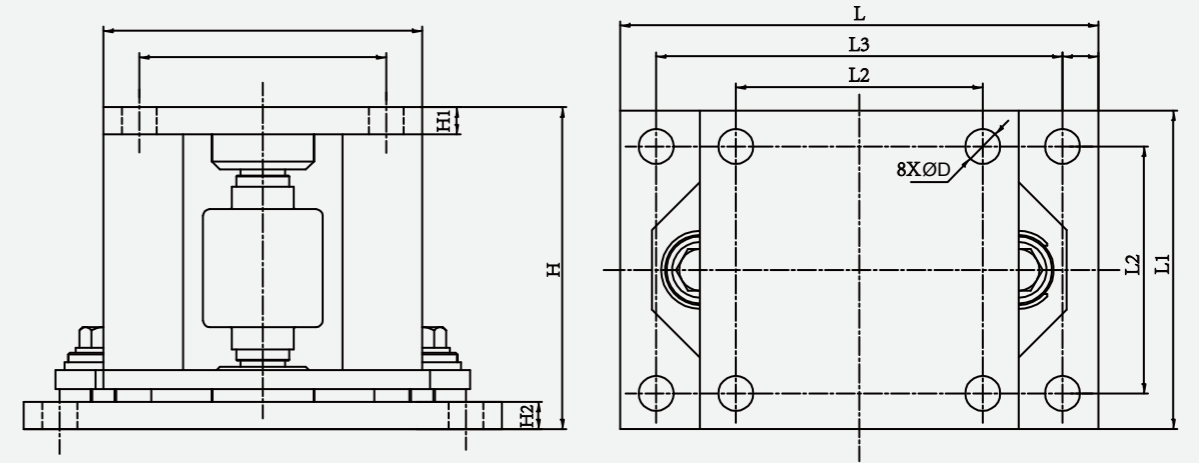

Cap(unit:t)	D	H	H1	H2	L	L1	L2	L3	L4
7.5~22.5	22	152	12	17	300	200	155	255	22.5
25~70	22	200	17	17	300	200	155	255	22.5
100	32	263	30	33	440	300	235	375	32.5

# GML-M410



## 柱式模块

Weighing module with canister load cells

适用于GML-Z4 A系列传感器;  
结构紧凑, 安装简便;  
不锈钢及合金钢材质可选.

GML-Z4 A series are apply to this module;  
Compact installation, easy installation;  
Stainless steel and alloy steel selection.

单位 Unit: mm

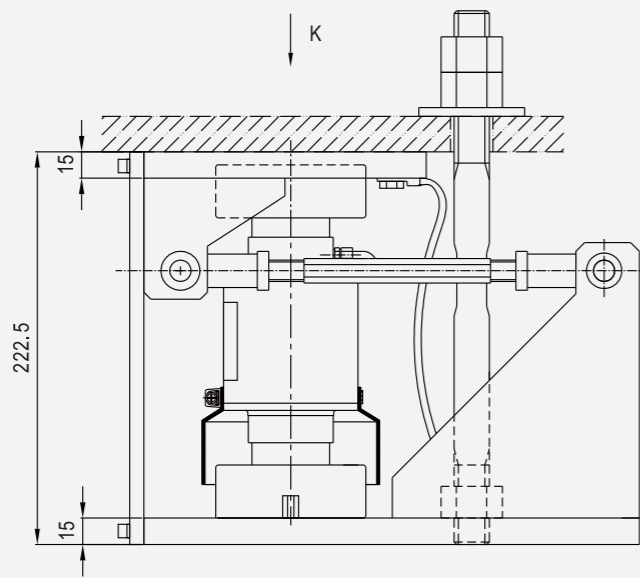

Top view, 顶视图, 无容器脚  
drawing without tank foot

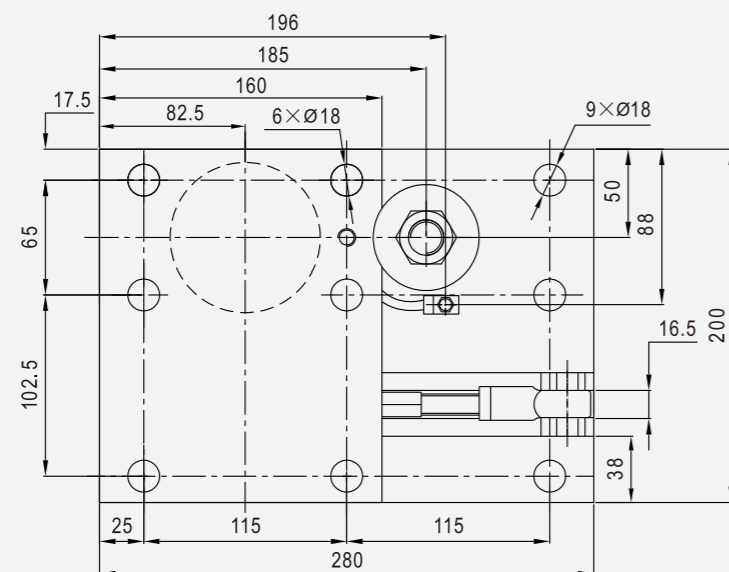

## Mounting examples for weighing modules with stay rods: 带有支撑杆的称重模块安装示例

Cylindrical arrangement of the weighing module below tanks  
称重模块在罐下部的圆形布置

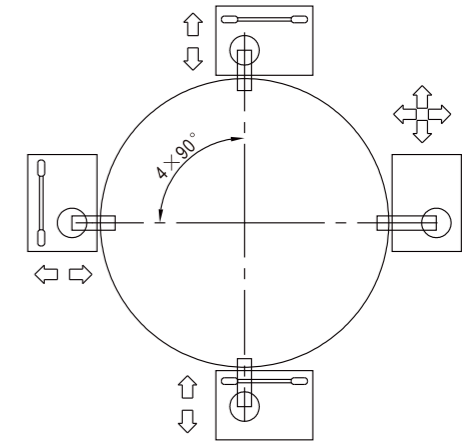
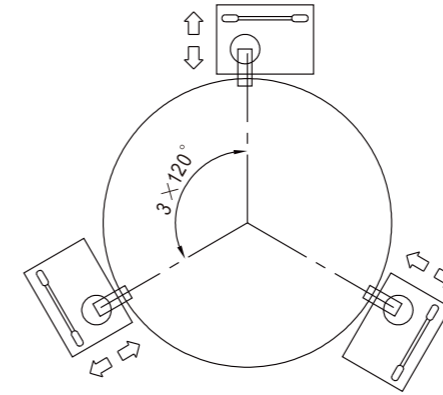

Rectangular arrangement of the weighing module below tanks  
称重模块在罐下部的方形布置

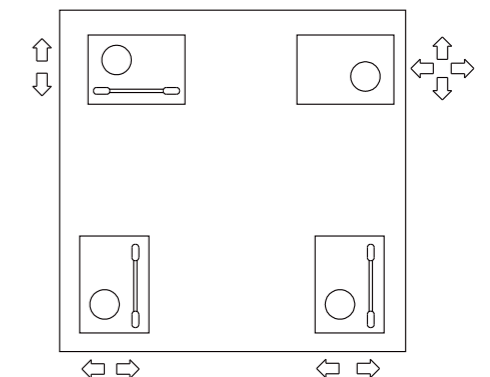
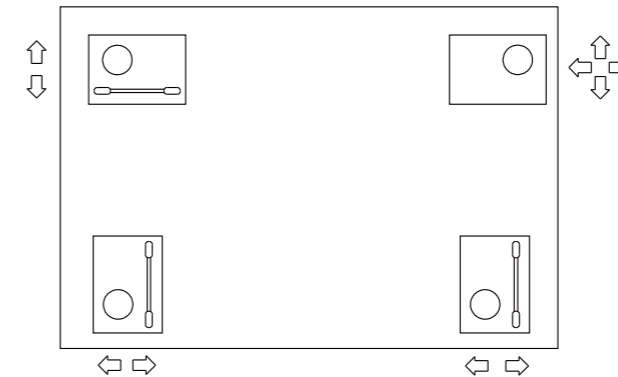

Remark备注: Stay rod 支撑杆 Load introduction 负载方向 Degree of freedom 自由度

## Further accessory: 其他附件

Fixed bearings with the same installation height as the weighing module.  
固定底座与称重模块是同样的高度; 安装时具有替代作用。

